



PULS • ARH



MONTENEGRO AND DEVELOPMENT PROCESS, an example

M. Kostić, B. Glumac, I. Nikolić, I. Rašković, A. Ivanović, M. Mačkić, I. Mačkić, K. Kostić

Introuduction

Method

Case study

Implication
and
conclusions

Montenegro real estate market



Introduction

Method

Case study

Implication
and
conclusions

REASON:

Our clients . . .

. . . need for consulting in urban and architectural design in early phases of Greenfield development.

. . . overlooking and omission of **benefits** that urban and architectural design could provide in early phases of Greenfield development.



Introduction

Method

Case study

Implication
and
conclusions

AIM:

- exploring the possibilities in use of urban and architectural design in qualitative research in development process.
- research how urban and architectural design in early stages of development process could affect creating a development strategy
- exploring new possibilities for implementation urban and architectural design in development process



Introduction

Method

Case study

Implication
and
conclusions

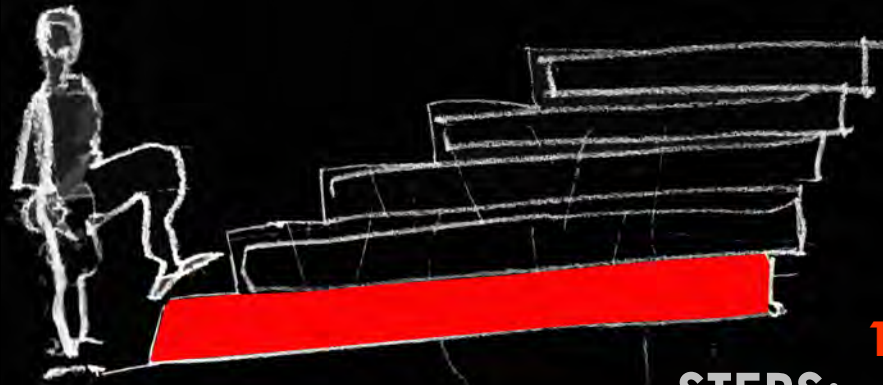

1. ANALYSIS
STEPS:



Introduction

Method

Case study

Implication
and
conclusions



2. SELECTION

1. ANALYSIS

STEPS:



Introduction

Method

Case study

Implication
and
conclusions

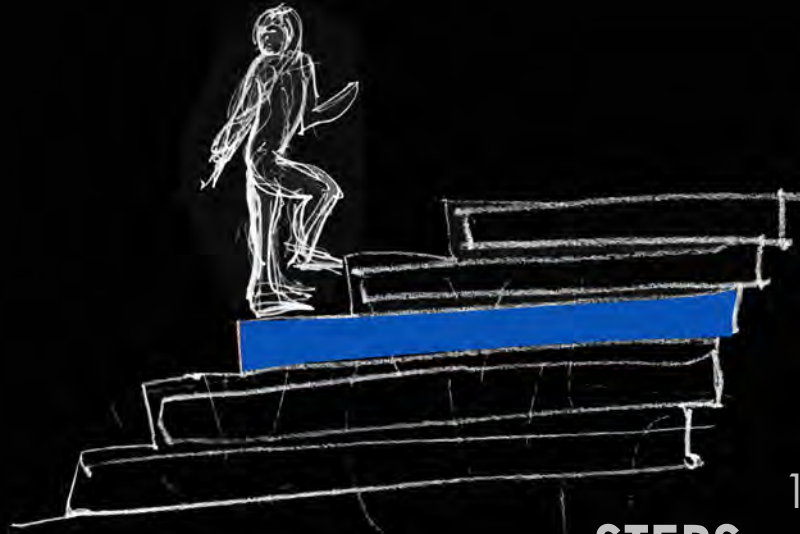

3. COMPARISON

2. SELECTION

1. ANALYSIS

STEPS:



Introduction

Method

Case study

Implication
and
conclusions

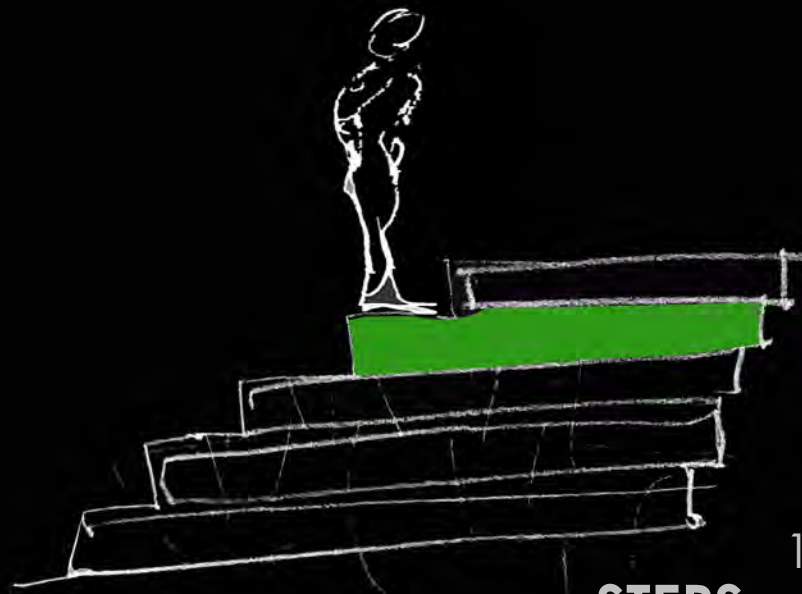

4. CONCEPT SOLUTION

3. COMPARISON

2. SELECTION

1. ANALYSIS

STEPS:



Introduction

Method

Case study

Implication
and
conclusions

1. ANALYSIS

Client
demands



Introduction

Method

Case study

Implication
and
conclusions

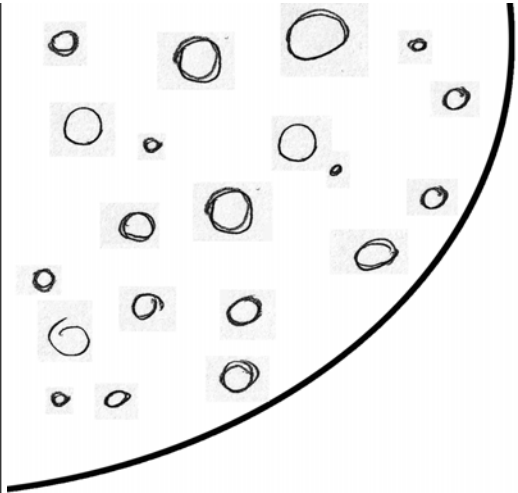

1. ANALYSIS



Introduction

Method

Case study

Implication
and
conclusions

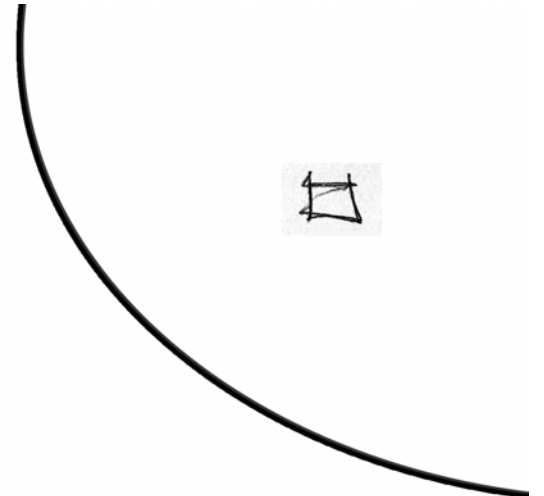
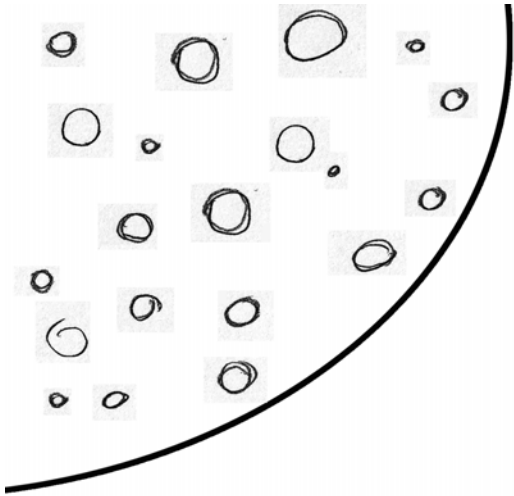

1. ANALYSIS



Introduction

Method

Case study

Implication
and
conclusions

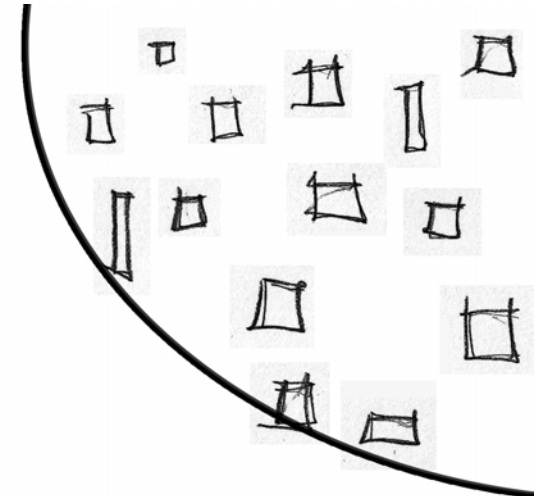
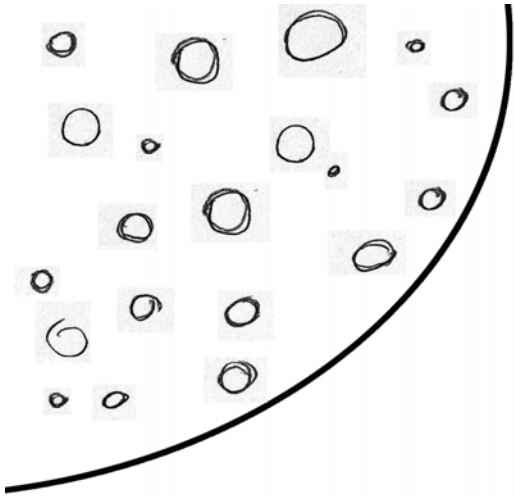

1. ANALYSIS

Client demands

Location characteristics



Introduction
Method
Case study
Implication and conclusions

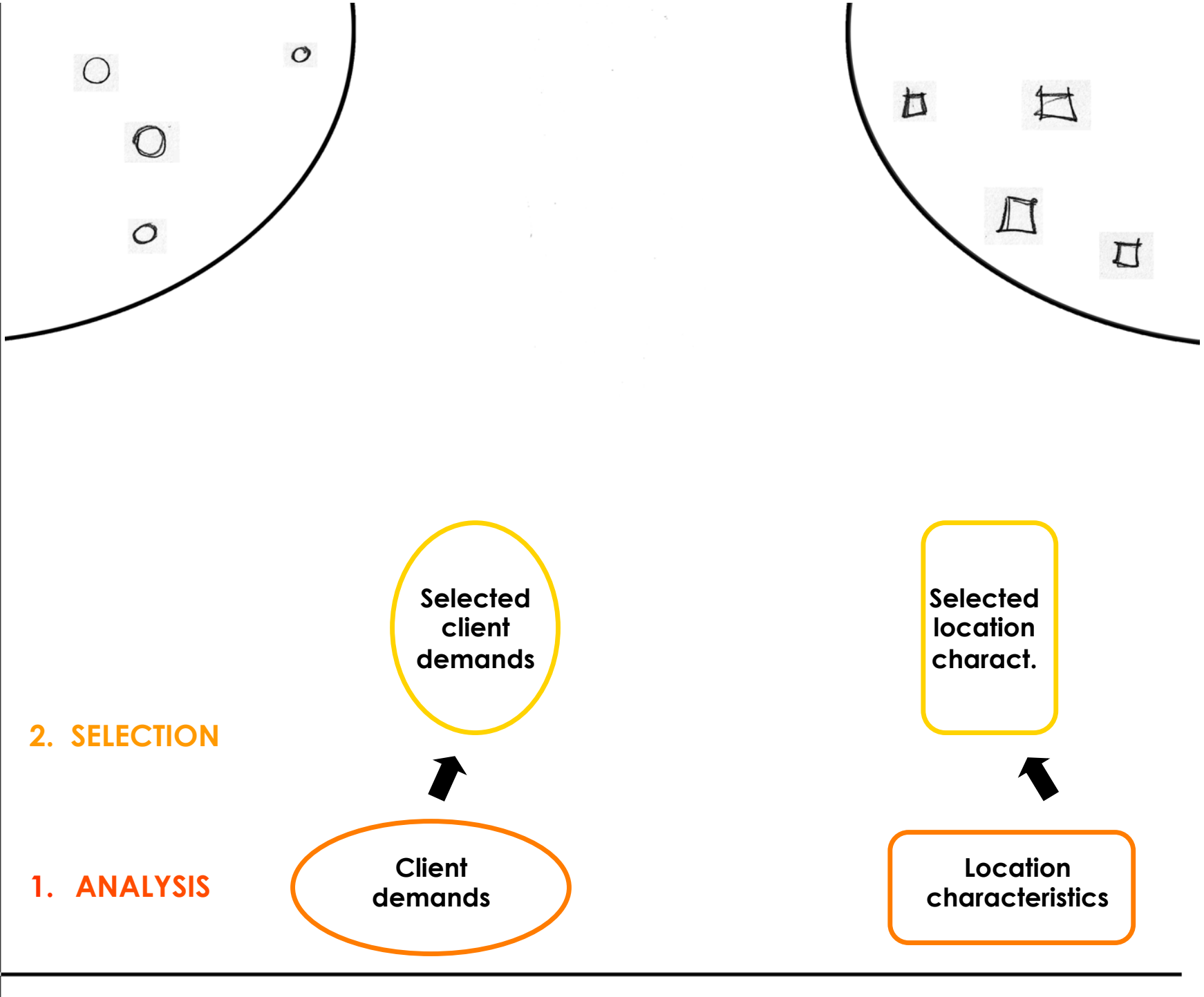

Introduction

Method

Case study

Implication and conclusions

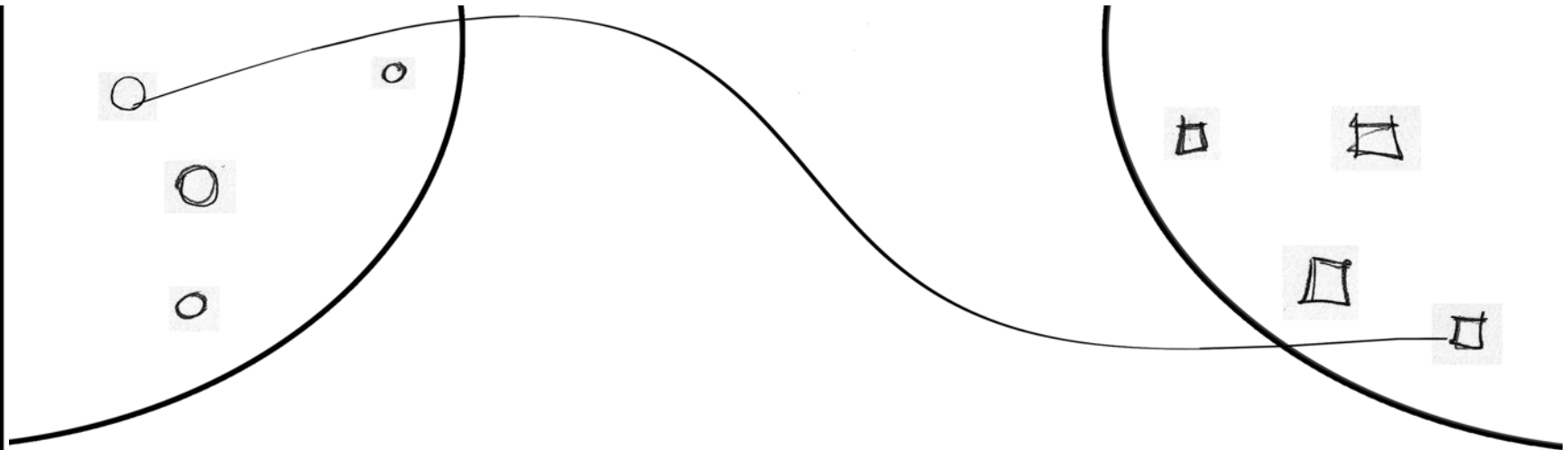

3. COMPARISON

2. SELECTION

1. ANALYSIS

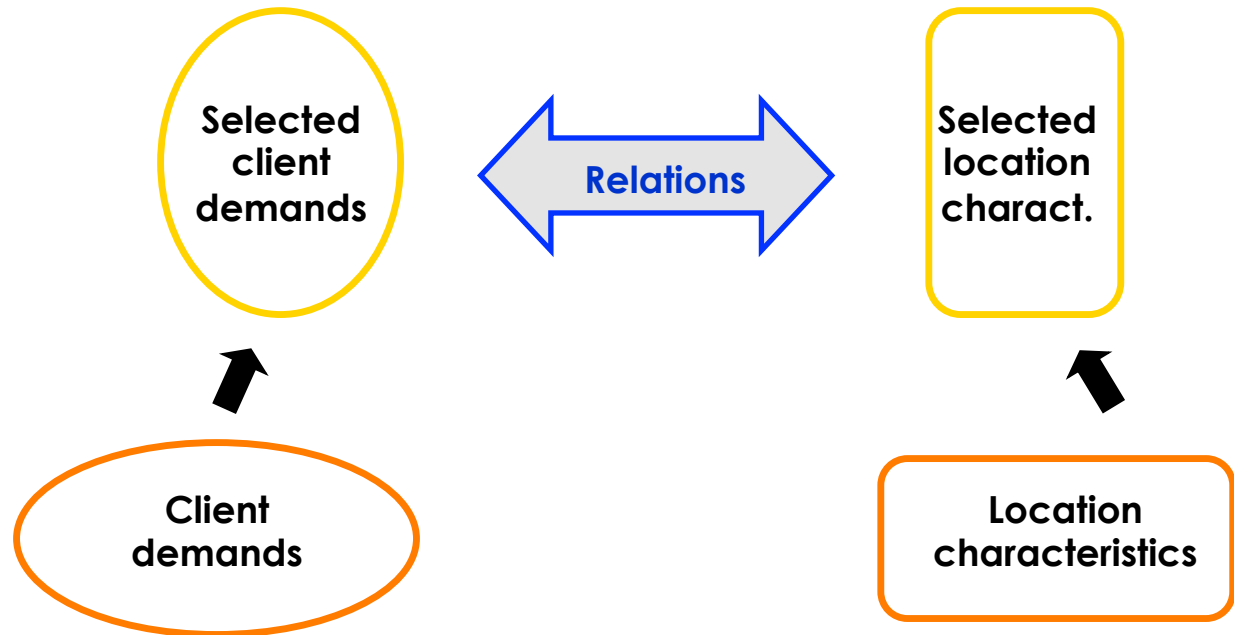

Introduction

Method

Case study

Implication and conclusions

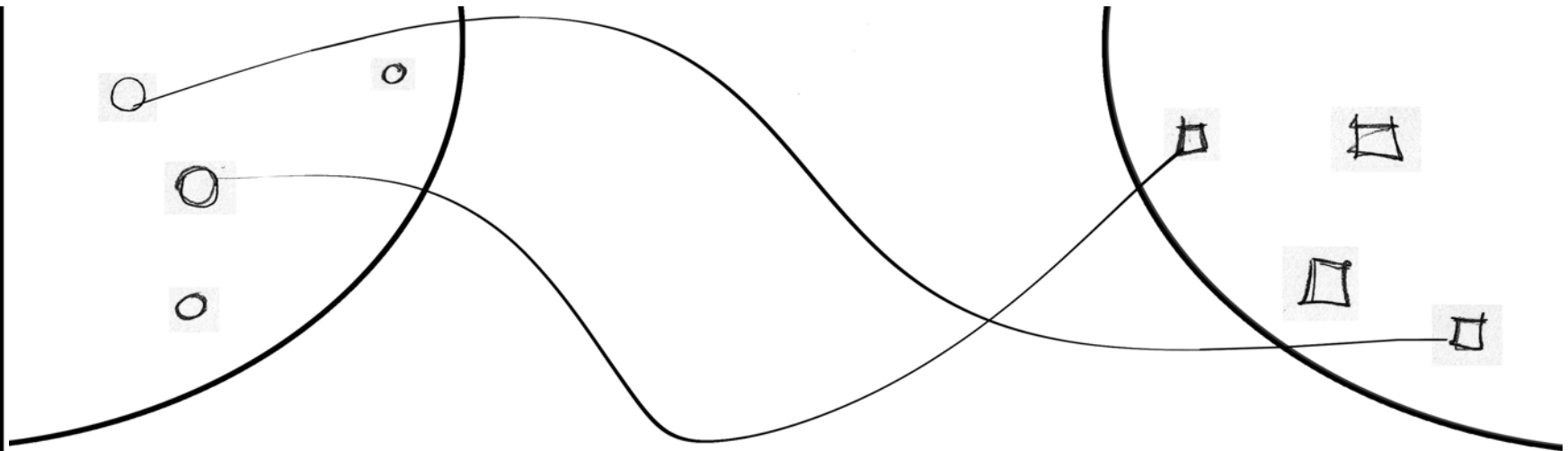

3. COMPARISON

Selected client demands



Selected location charact.

2. SELECTION



1. ANALYSIS

Client demands

Location characteristics



Introduction
Method
Case study
Implication and conclusions

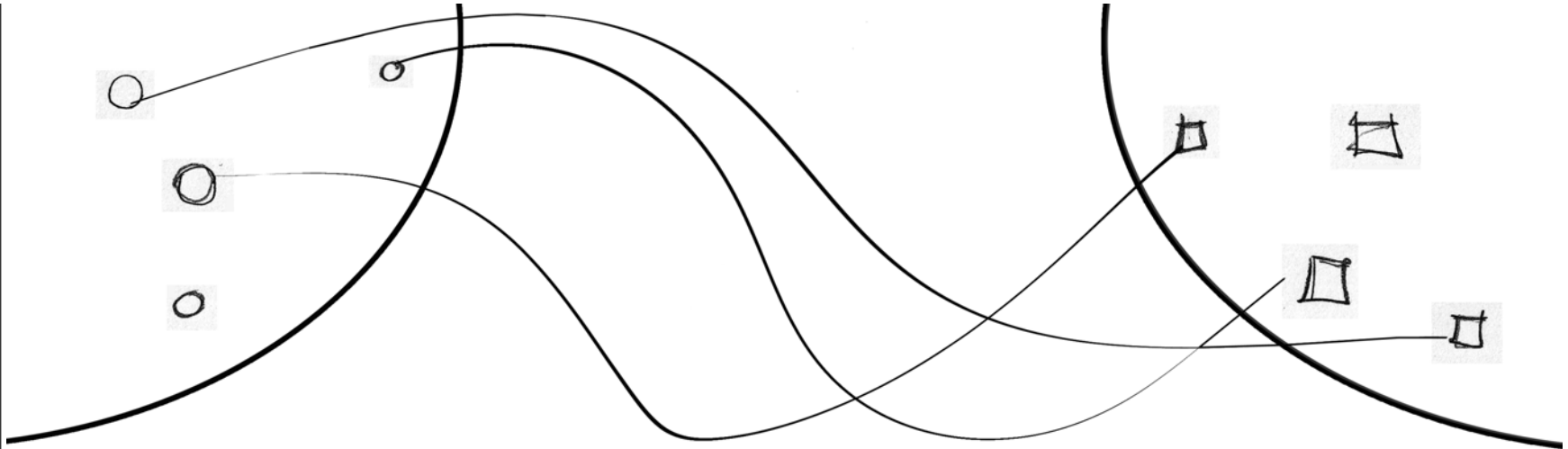

3. COMPARISON

Selected client demands



Selected location charact.

2. SELECTION



1. ANALYSIS

Client demands

Location characteristics

Introduction

Method

Case study

Implication and conclusions

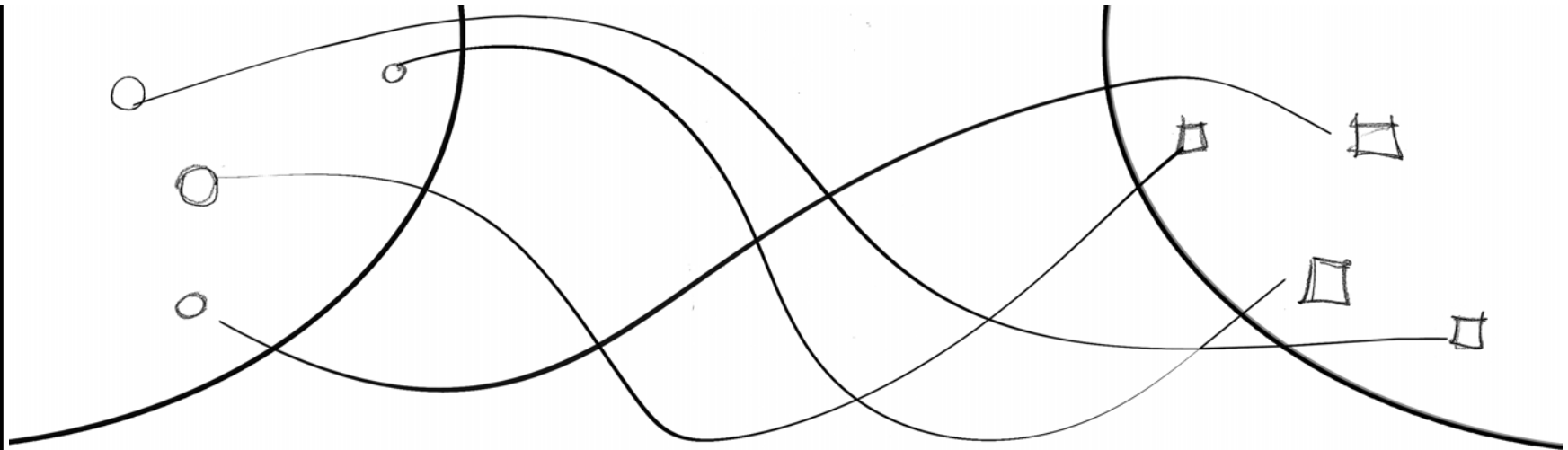

3. COMPARISON

Selected client demands



Selected location charact.

2. SELECTION



1. ANALYSIS

Client demands

Location characteristics



Introduction

Method

Case study

Implication and conclusions

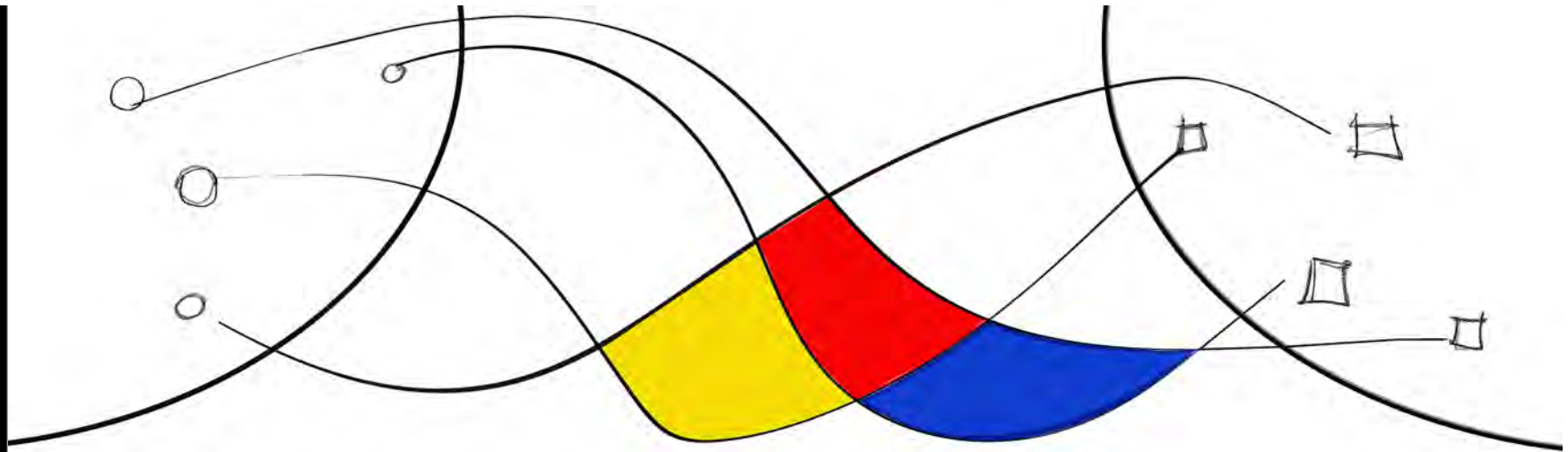

3. COMPARISON

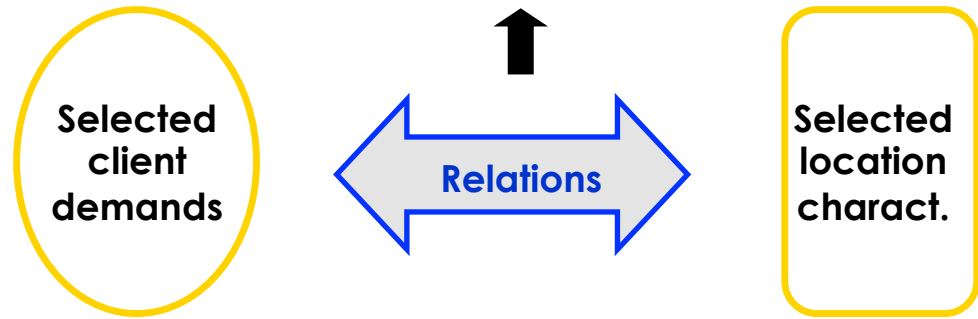

2. SELECTION



1. ANALYSIS



Architectural Concept Solution

Introduction

Method

Case study

Implication and conclusions



4. CONCEPT SOLUTION



3. COMPARISON

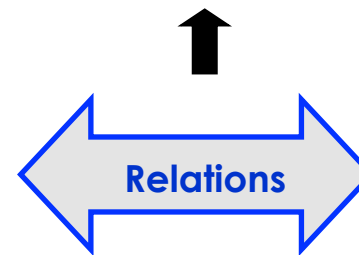

2. SELECTION

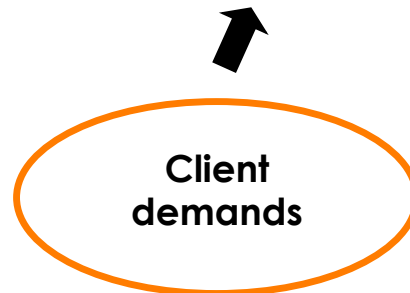

1. ANALYSIS



Introduction

Method

Case study

Implication and conclusions

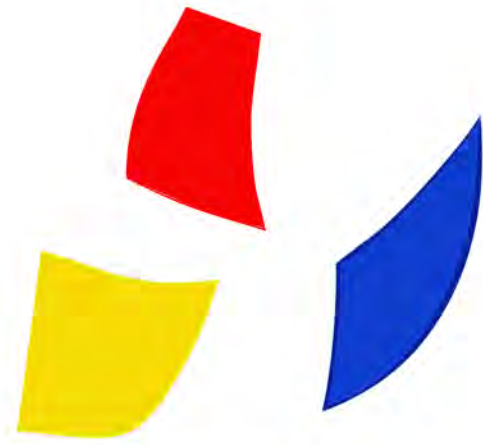

4. CONCEPT SOLUTION



3. COMPARISON

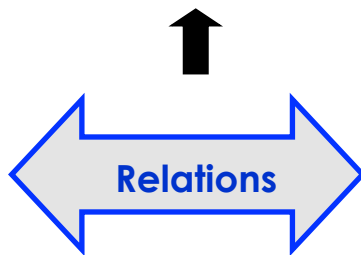

2. SELECTION



1. ANALYSIS



Introduction

Method

Case study

Implication and conclusions



4. CONCEPT SOLUTION



3. COMPARISON

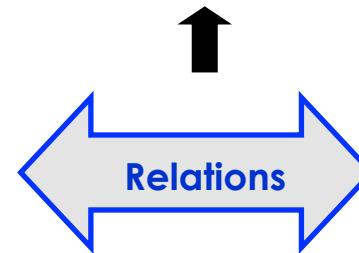

2. SELECTION

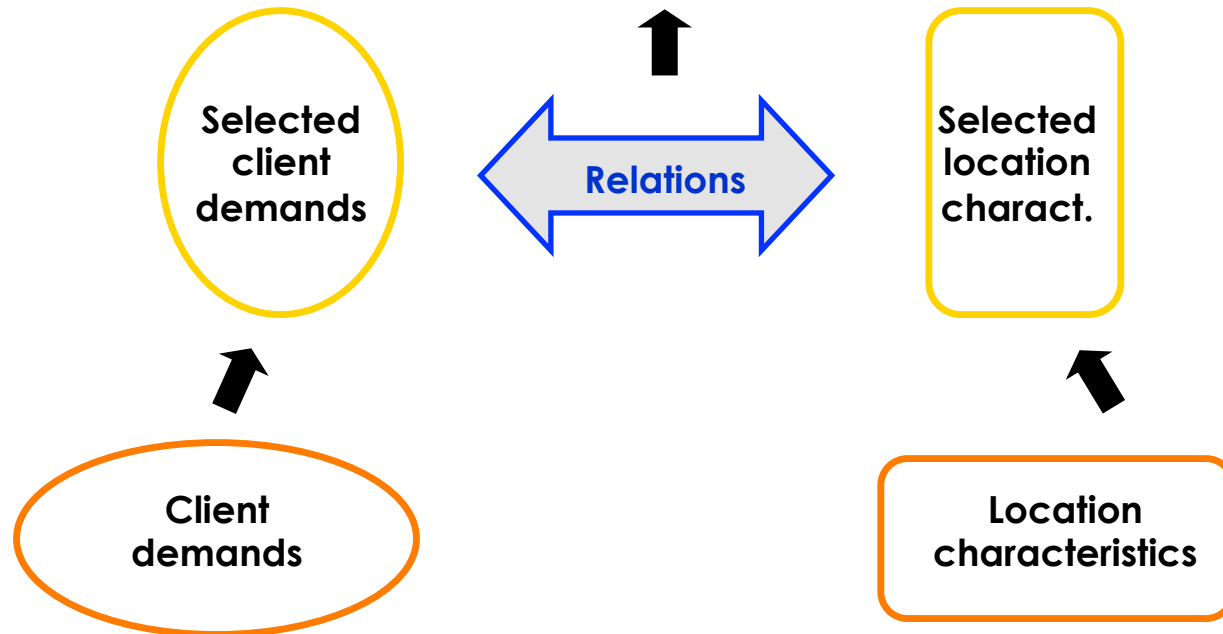

1. ANALYSIS



Introduction

Method

Case study

Implication and conclusions



4. CONCEPT SOLUTION



3. COMPARISON

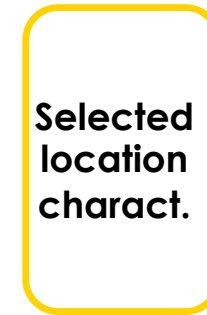
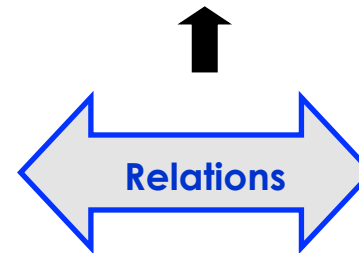
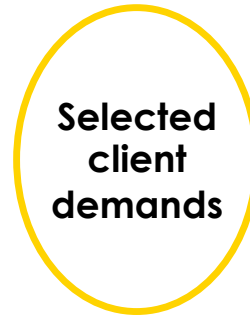

2. SELECTION

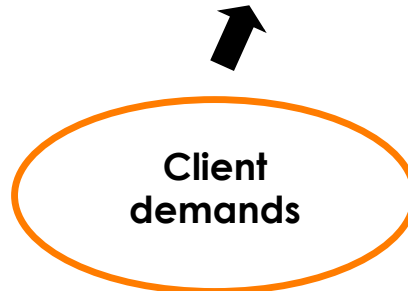

1. ANALYSIS



Introduction

Method

Case study

Implication and conclusions



4. CONCEPT SOLUTION



3. COMPARISON

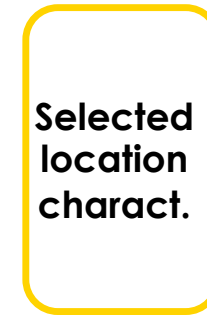
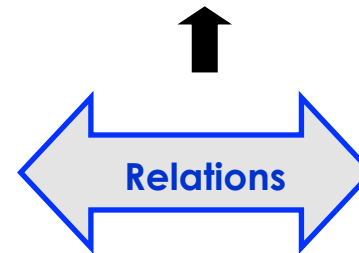

2. SELECTION

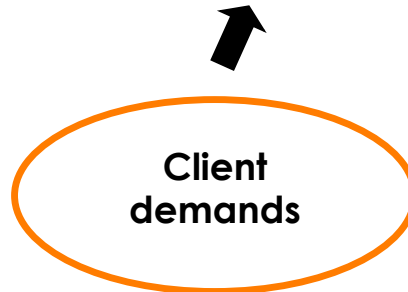

1. ANALYSIS



Introduction

Method

Case study

Implication
and
conclusions

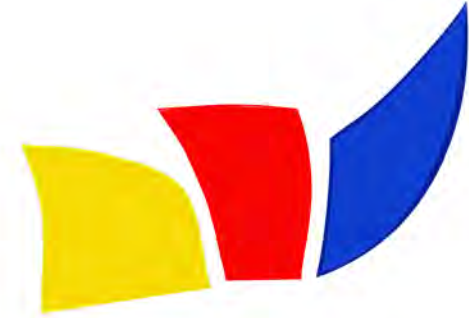

4. CONCEPT SOLUTION

3. COMPARISON

2. SELECTION

1. ANALYSIS



EXAMPLE : Conference center

Introduction

Method

Case study

Implication
and
conclusions

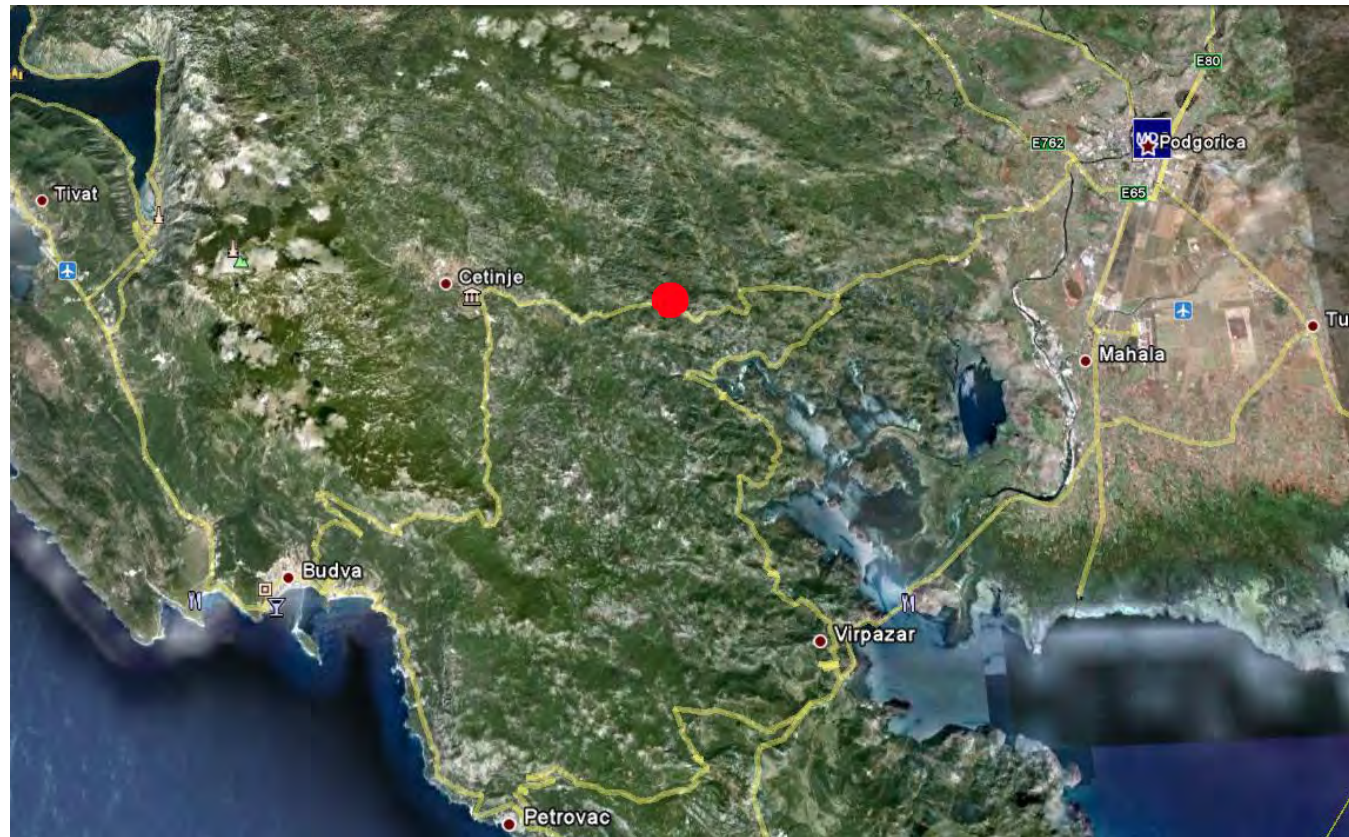

EXAMPLE :
Conference center

Introduction

Method

Case study

Implication
and
conclusions

ANALYSIS



EXAMPLE :
Conference center

Introduction

Method

Case study

Implication
and
conclusions

ANALYSIS

Client demands

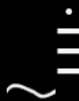

Introduction

Method

Case study

Implication
and
conclusions



Client demands

EXAMPLE :
Conference center

ANALYSIS

- exclusivity

Introduction

Method

Case study

Implication
and
conclusions

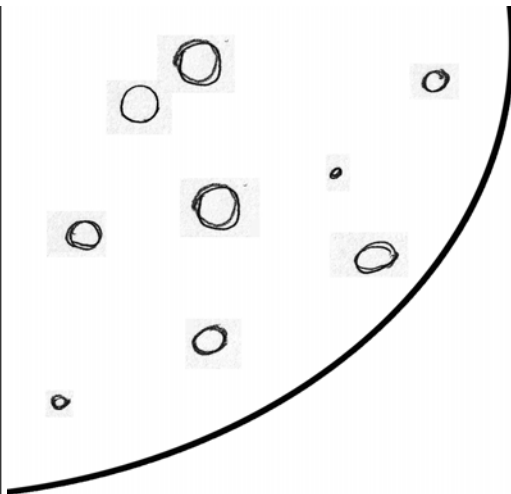

EXAMPLE :
Conference center

ANALYSIS

- exclusivity
- business facilities
- spatial separation of facilities
- creating landmark
- leisure facilities
- accomodation facilities
- boutiques
- exceptional accessibility
- panoramic view

Client demands



Introduction

Method

Case study

Implication
and
conclusions

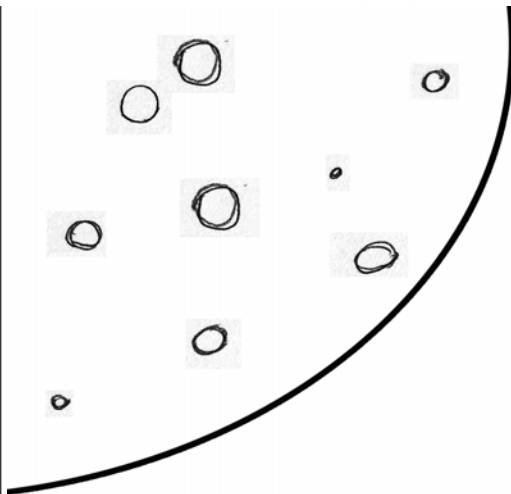

EXAMPLE :
Conference center

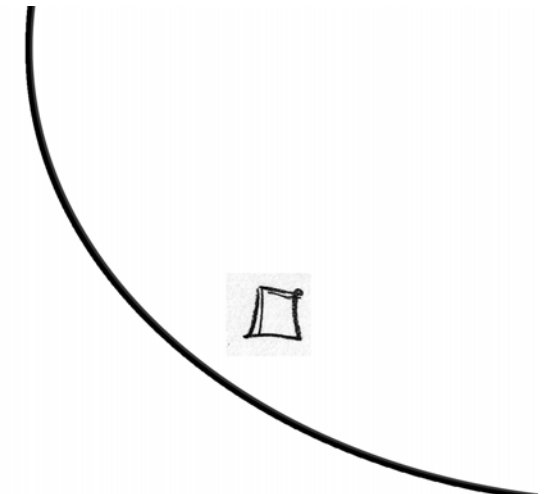

ANALYSIS

- exclusivity
- business facilities
- spatial separation of facilities
- creating landmark
- leisure facilities
- accomodation facilities
- boutiques
- exceptional accessibility
- panoramic view

- site location

Client demands

Location analysis



Introduction

Method

Case study

Implication
and
conclusions

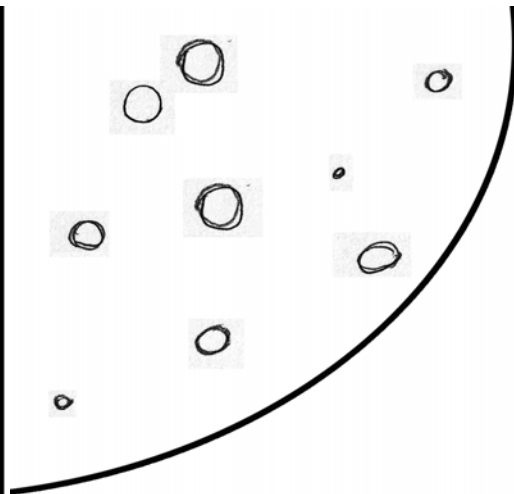

EXAMPLE :
Conference center

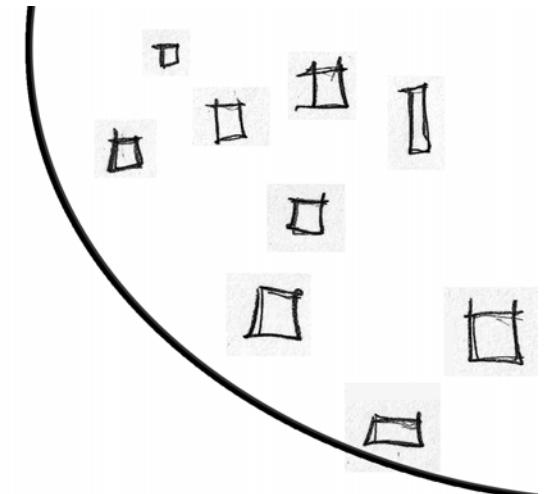

ANALYSIS

- exclusivity
- business facilities
- spatial separation of facilities
- creating landmark
- leisure facilities
- accomodation facilities
- boutiques
- exceptional accessibility
- panoramic view

Client demands

- site location
- site accessibility
- site morfology
- soil structure
- site orientation
- exposure to main road
- existing instalations
- site environment
- microclimate conditions

Location analysis

Introduction

Method

Case study

Implication
and
conclusions

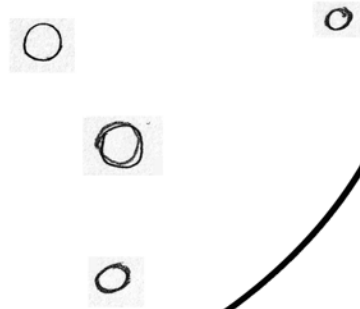

EXAMPLE :
Conference center

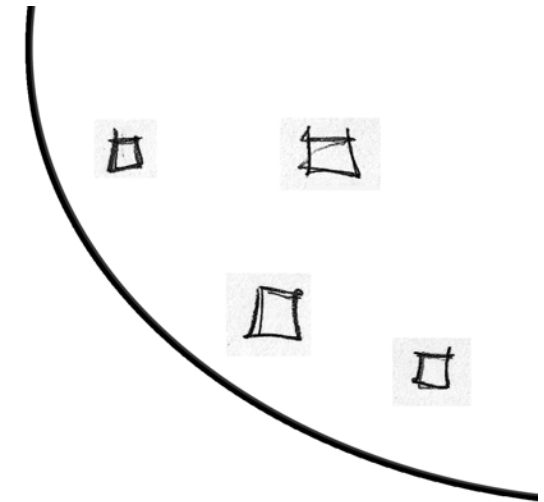

SELECTION

- **exclusivity**
- business facilities
- **spatial separation of facilities**
- **creating landmark**
- leisure facilities
- accomodation facilities
- boutiques
- **exceptional accessibility**
- panoramic view

Client demands

- **site location**
- **site accessibility**
- **site morfology**
 - soil structure
 - site orientation
- **exposure to main road**
 - existing instalations
 - site environment
- microclimate conditions

Location analysis

Introduction

Method

Case study

Implication
and
conclusions



SELECTION

- **exclusivity**

- spatial separation of facilities

- creating landmark

- exceptional accessibility

- site location
- site accessibility
- site morphology

- exposure to main road

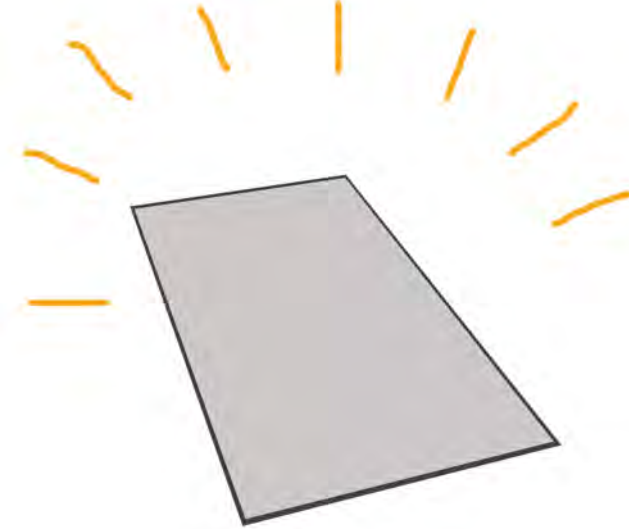

Client demands

Location analysis

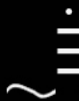

Introduction

Method

Case study

Implication
and
conclusions

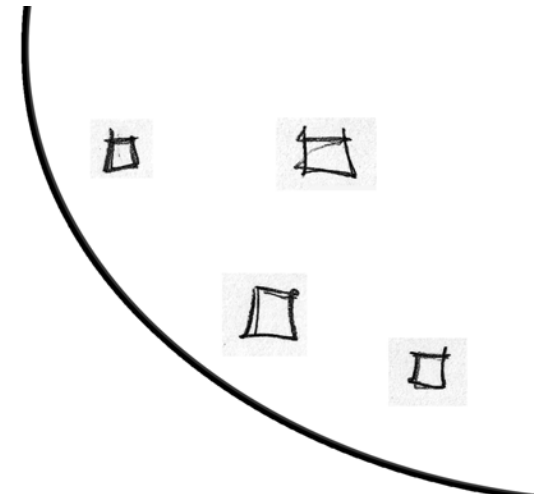
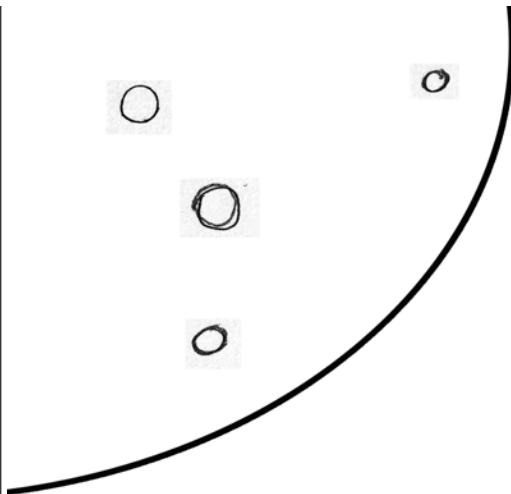

SELECTION

- exclusivity
- **spatial separation of facilities**
- creating landmark
- exceptional accessibility

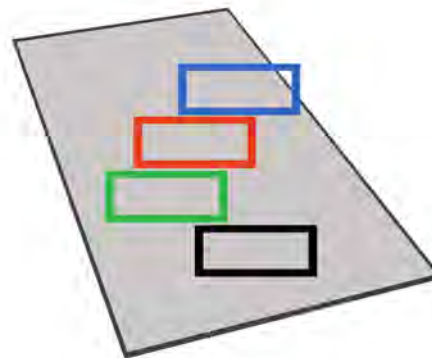

- site location
- site accessibility
- site morfology
- exposure to main road

Client demands

Location analysis

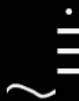

Introduction

Method

Case study

Implication
and
conclusions

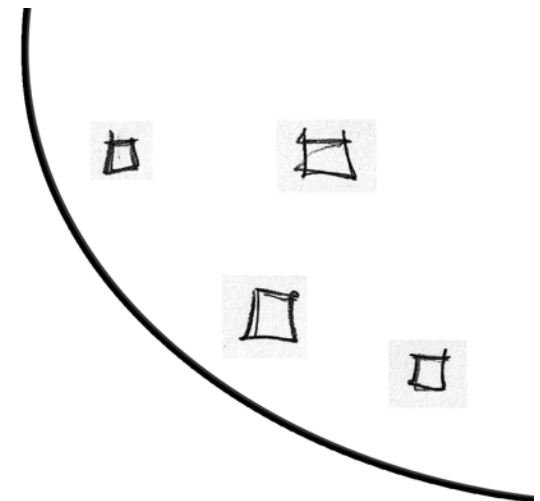
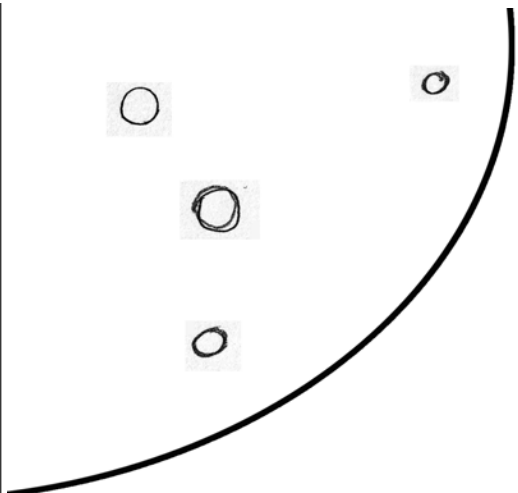

SELECTION

- exclusivity

- spatial separation of facilities

- **creating landmark**

- exceptional accessibility

- site location

- site accessibility

- site morphology

- exposure to main road

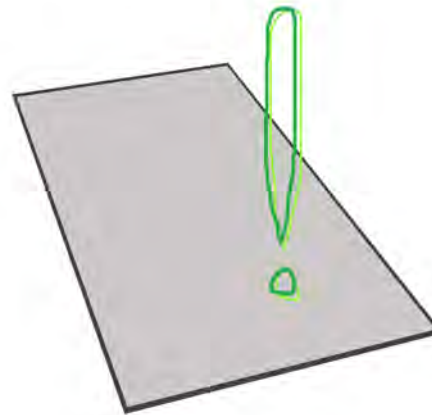

Client demands

Location analysis



Introduction

Method

Case study

Implication
and
conclusions



SELECTION

- exclusivity
- spatial separation of facilities
- creating landmark

- site location
- site accessibility
- site morfology



- exposure to main road

- **exceptional accessibility**

Client demands

Location analysis

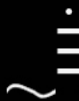

Introduction

Method

Case study

Implication and conclusions



SELECTION

- exclusivity

- spatial separation of facilities

- creating landmark

- exceptional accessibility

- **site location**

- site accessibility

- site morfology

- exposure to main road

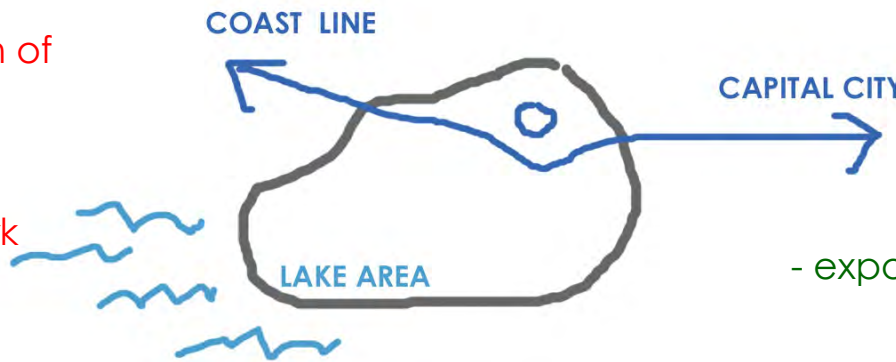

Client demands

Location analysis



Introduction

Method

Case study

Implication and conclusions



SELECTION

- exclusivity
- spatial separation of facilities
- creating landmark
- exceptional accessibility
-

- site location
- site accessibility
- **site morfology**
- exposure to main road

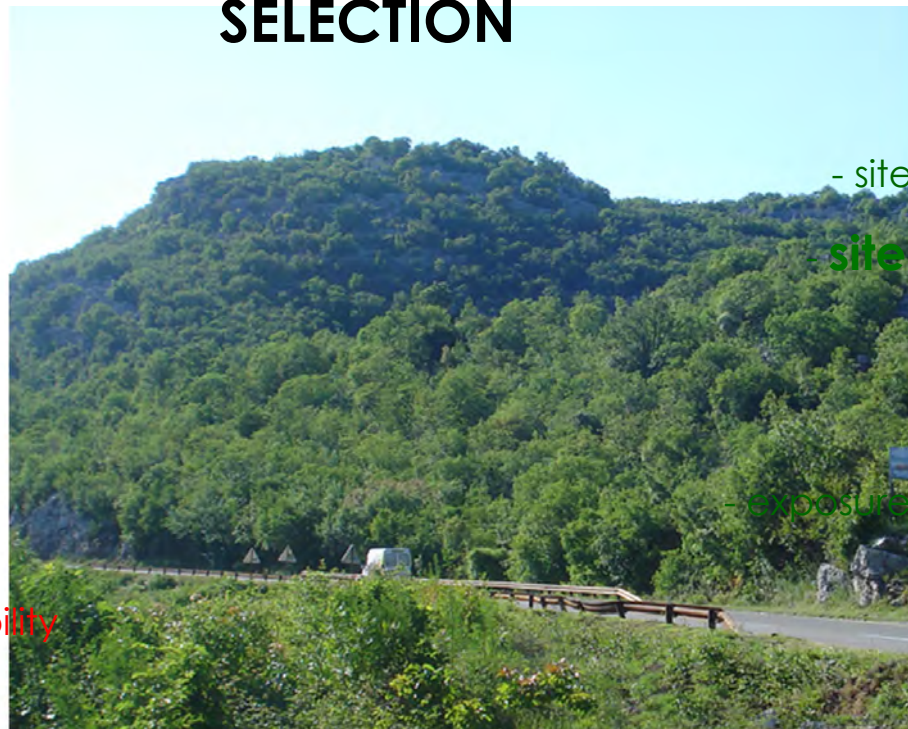

Client demands

Location analysis



Introduction

Method

Case study

Implication and conclusions



SELECTION

- exclusivity
- spatial separation of facilities
- creating landmark
- exceptional accessibility
-

- site location
- site accessibility
- **site morfology**
- exposure to main road



Client demands

Location analysis



Introduction

Method

Case study

Implication and conclusions

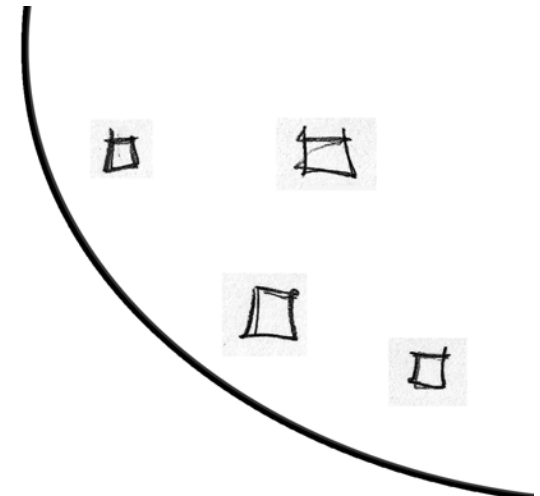
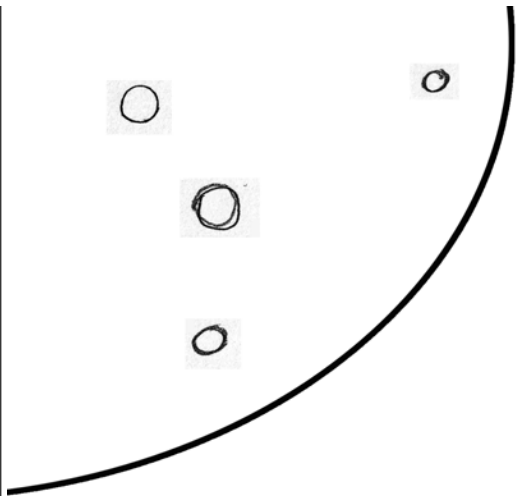

SELECTION

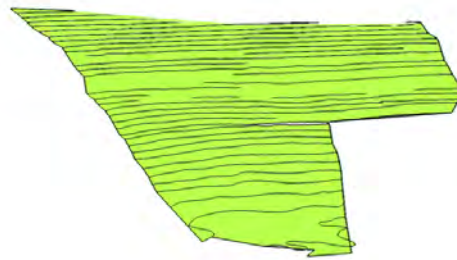

- exclusivity

- spatial separation of facilities

- creating landmark

- exceptional accessibility

-

Client demands

- site location

- site accessibility

- **site morphology**

- exposure to main road

Location analysis



Introduction

Method

Case study

Implication
and
conclusions

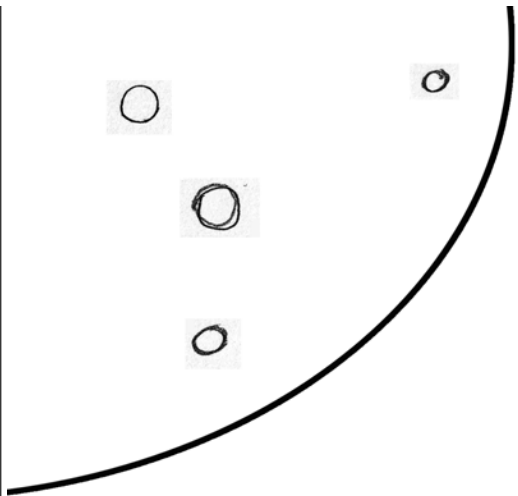

- exclusivity

- spatial separation of facilities

- creating landmark

- exceptional accessibility

-

Client demands

SELECTION

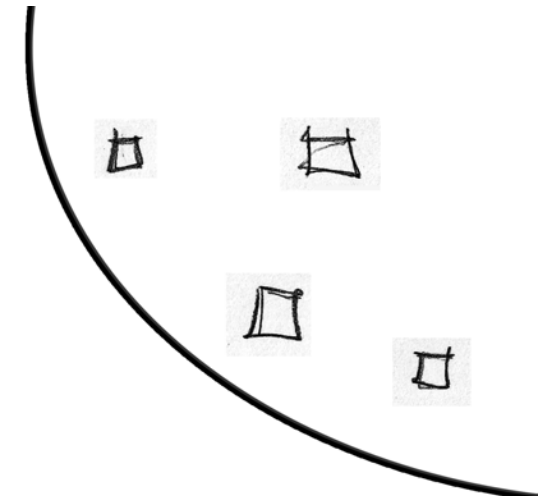
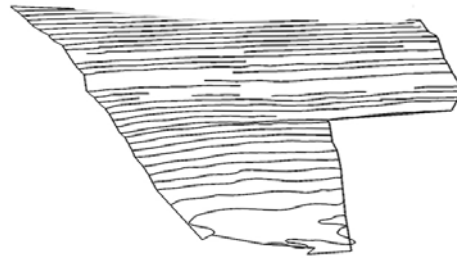

- site location

- site accessibility

- **site morphology**

- exposure to main road

Location analysis

Introduction

Method

Case study

Implication
and
conclusions

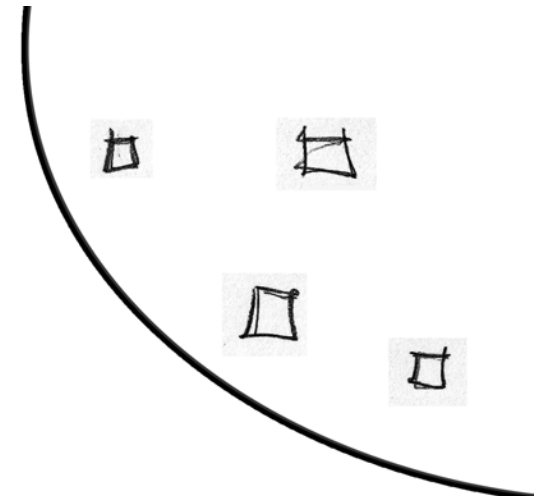
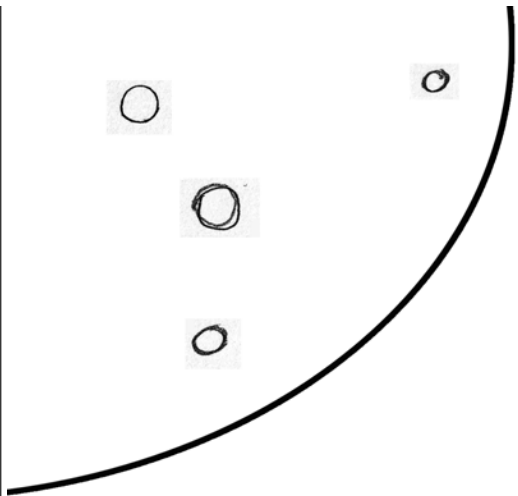

SELECTION

- exclusivity
- spatial separation of facilities
- creating landmark

- site location
- site accessibility
- **site morphology**

- exceptional accessibility
-

- exposure to main road

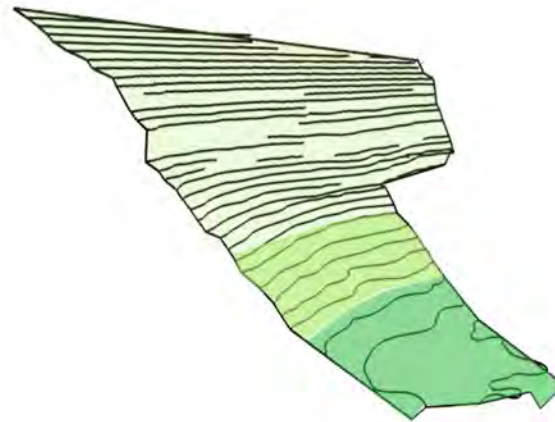

Client demands

Location analysis

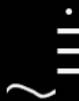

Introduction

Method

Case study

Implication and conclusions

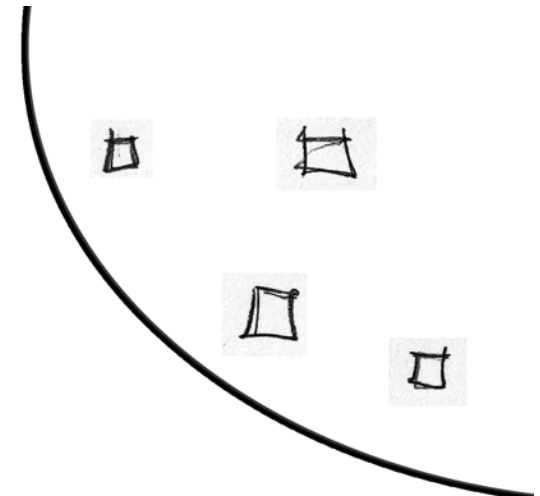
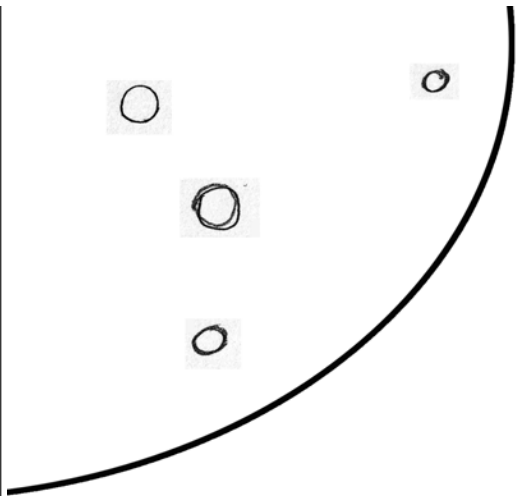

SELECTION

- exclusivity
- spatial separation of facilities
- creating landmark

- site location
- site accessibility
- **site morphology**

- exceptional accessibility
-

- exposure to main road

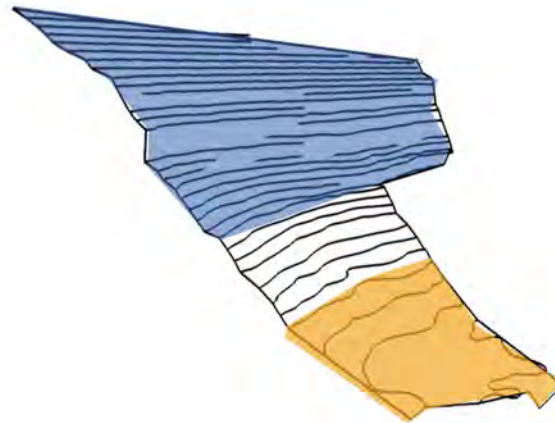

Client demands

Location analysis



Introduction

Method

Case study

Implication
and
conclusions

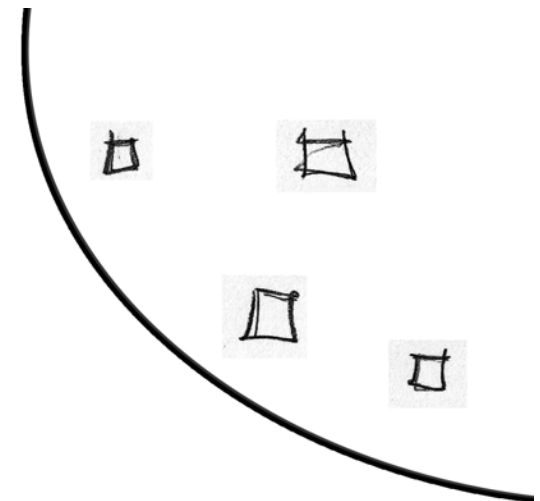
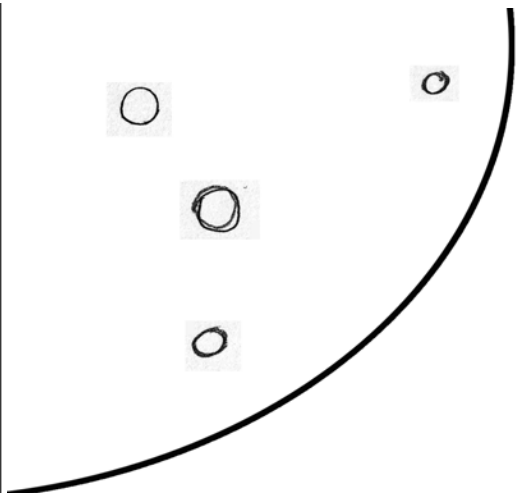

SELECTION

- exclusivity

- spatial separation of facilities

- creating landmark

- exceptional accessibility

-

Client demands

- site location

- site accessibility

- site morphology

- **exposure to main road**

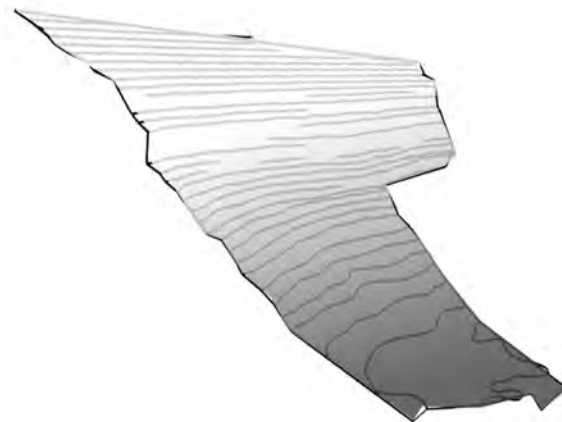

Location analysis



Introduction

Method

Case study

Implication
and
conclusions

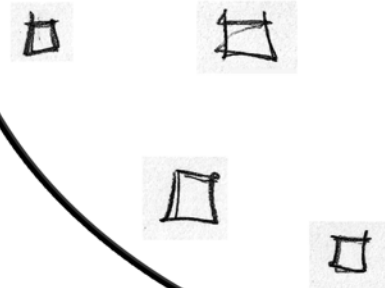
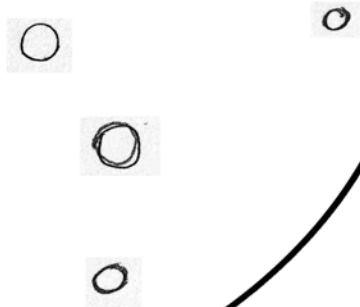

COMPARISON

- exclusivity

- spatial separation of facilities

- creating landmark

- exceptional accessibility

- site location

- site accessibility

- site morphology

- exposure to main road

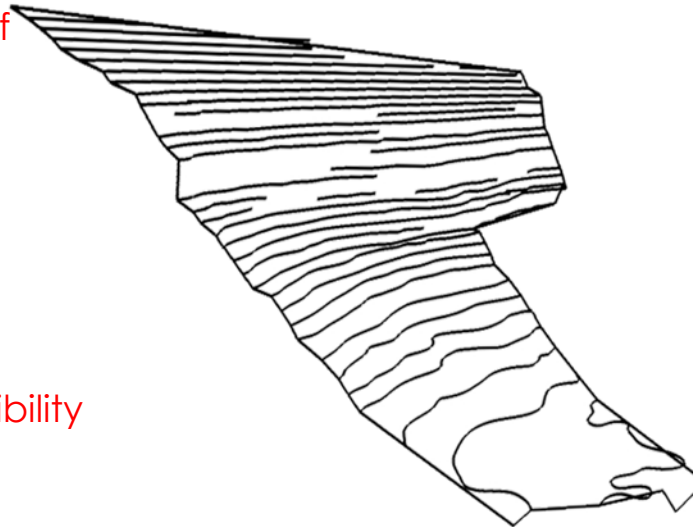

Client demands

Location analysis

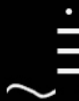

Introduction

Method

Case study

Implication
and
conclusions

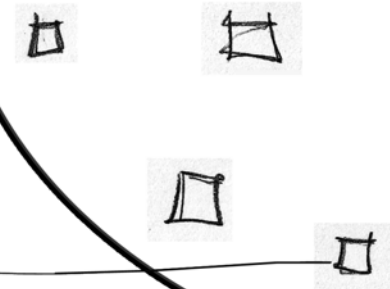
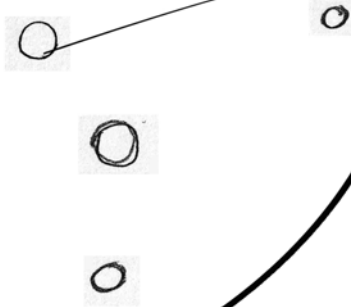

COMPARISON

- exclusivity

- **spatial separation of facilities**

- creating landmark

- exceptional accessibility

- **Client demands**

- site location

- site accessibility

- **site morphology**

- exposure to main road

Location analysis

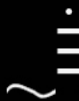
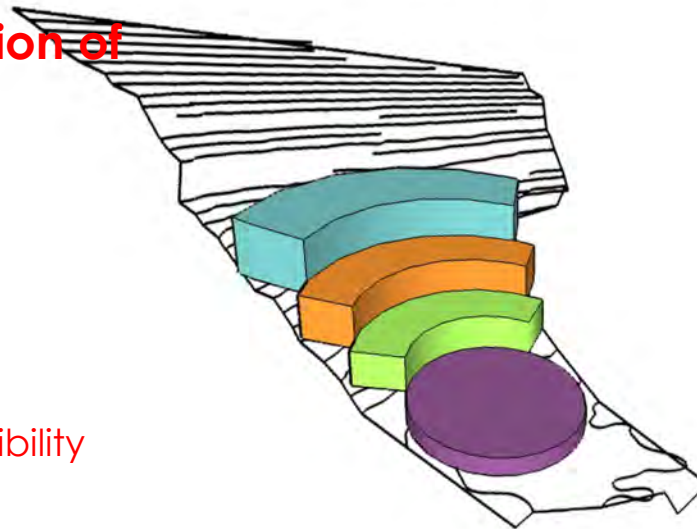

Introduction

Method

Case study

Implication
and
conclusions

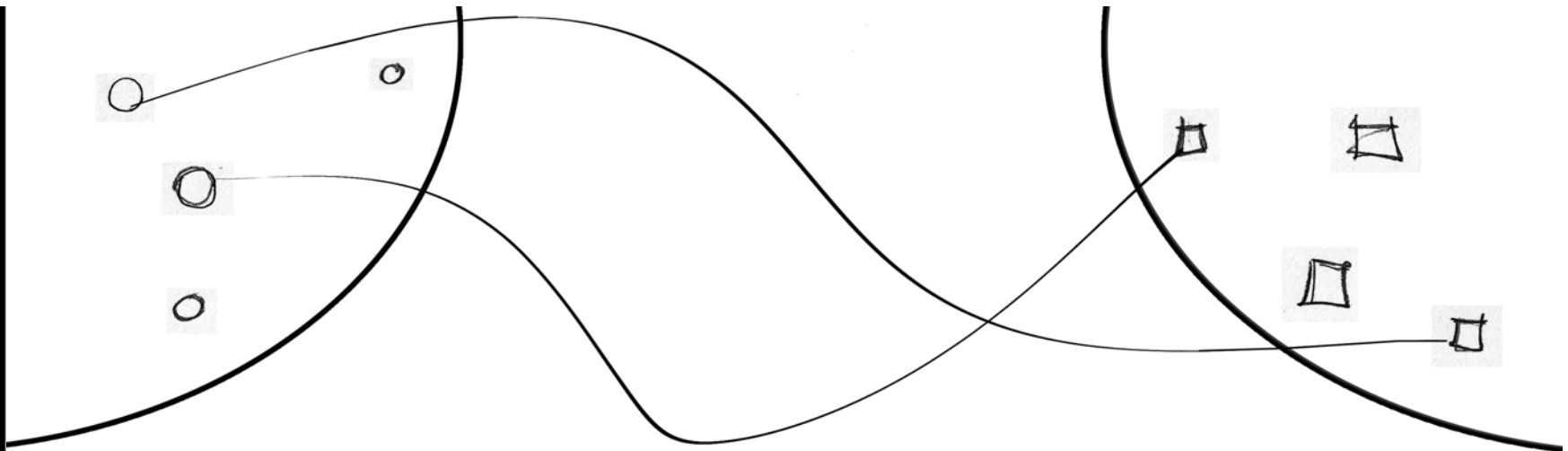

COMPARISON

- exclusivity

- spatial separation of facilities

- **creating landmark**

- exceptional accessibility

- site location

- site accessibility

- site morphology

- **exposure to main road**

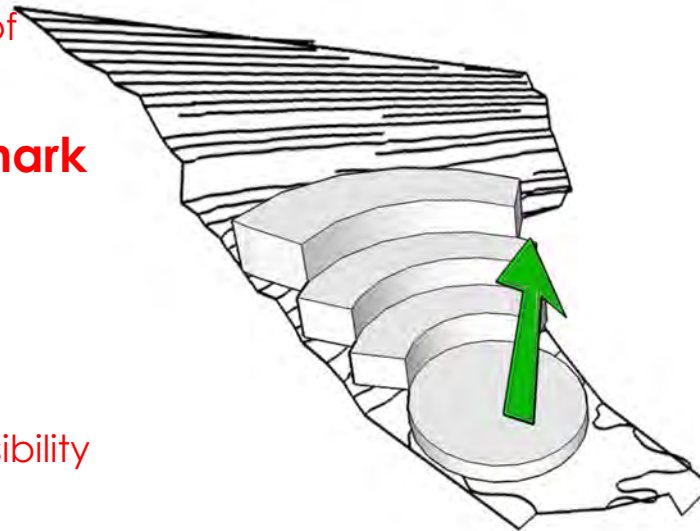

Client demands

Location analysis

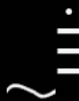

Introduction

Method

Case study

Implication
and
conclusions

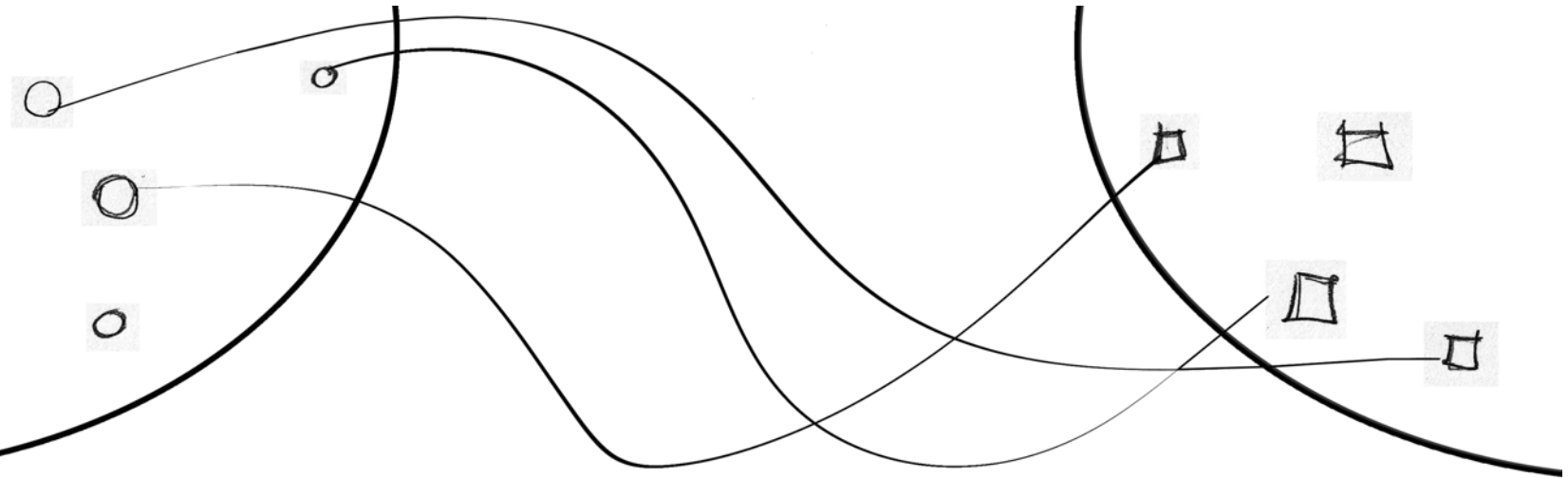

COMPARISON

- exclusivity

- spatial separation of facilities

- creating landmark

- **exceptional accessibility**

- site location

- site accessibility

- **site morphology**

- exposure to main road

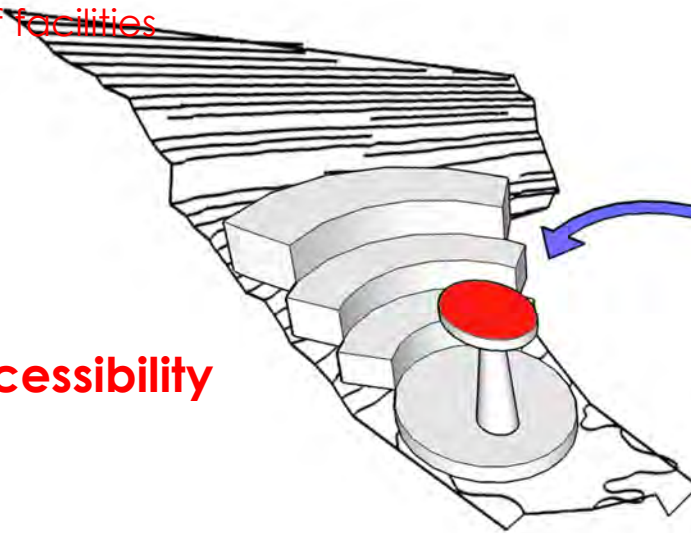

Client demands

Location analysis

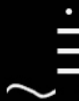

Introduction

Method

Case study

Implication
and
conclusions

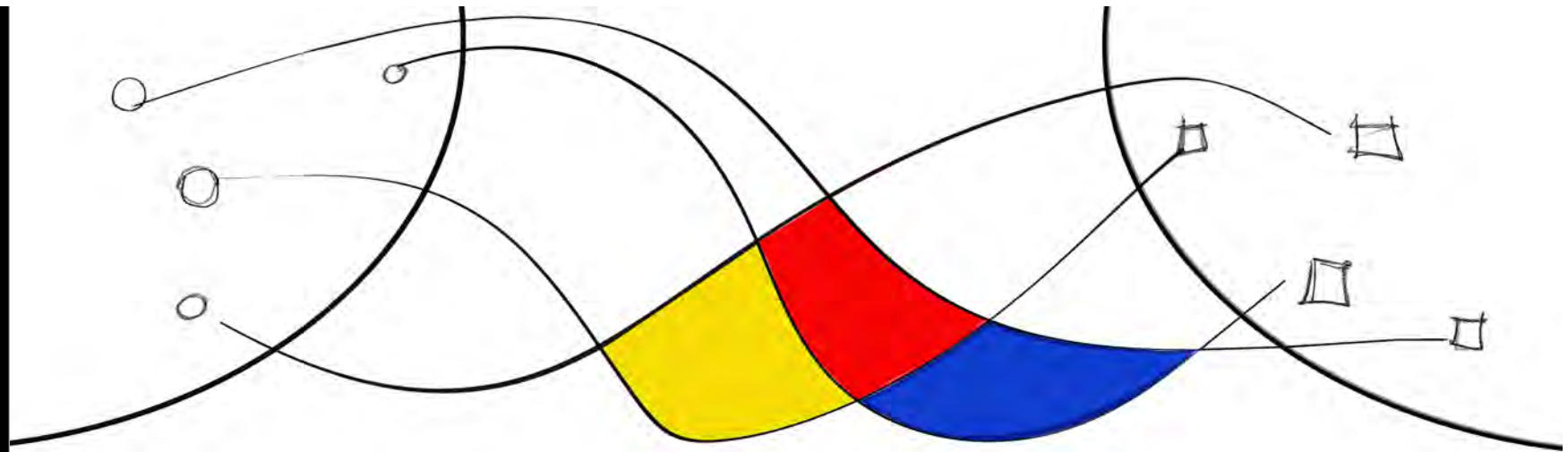

CONCEPT SOLUTION

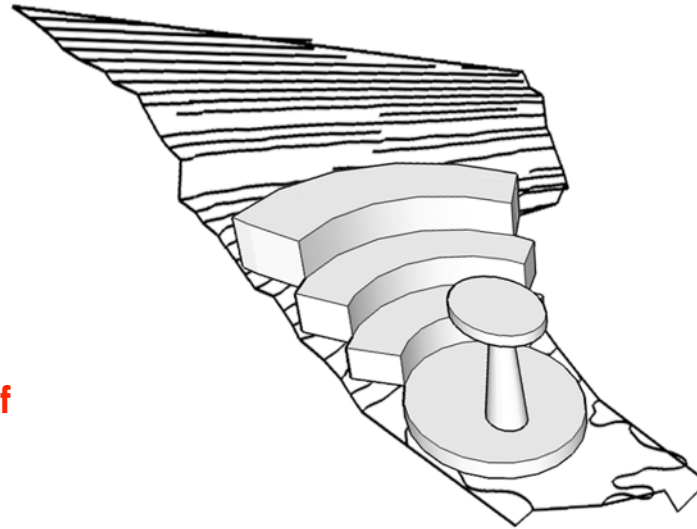

- exclusivity
- spatial separation of facilities
- creating landmark
- exceptional accessibility

- site location
- site accessibility
- site morphology
- exposure to main road



Introduction

Method

Case study

Implication
and
conclusions

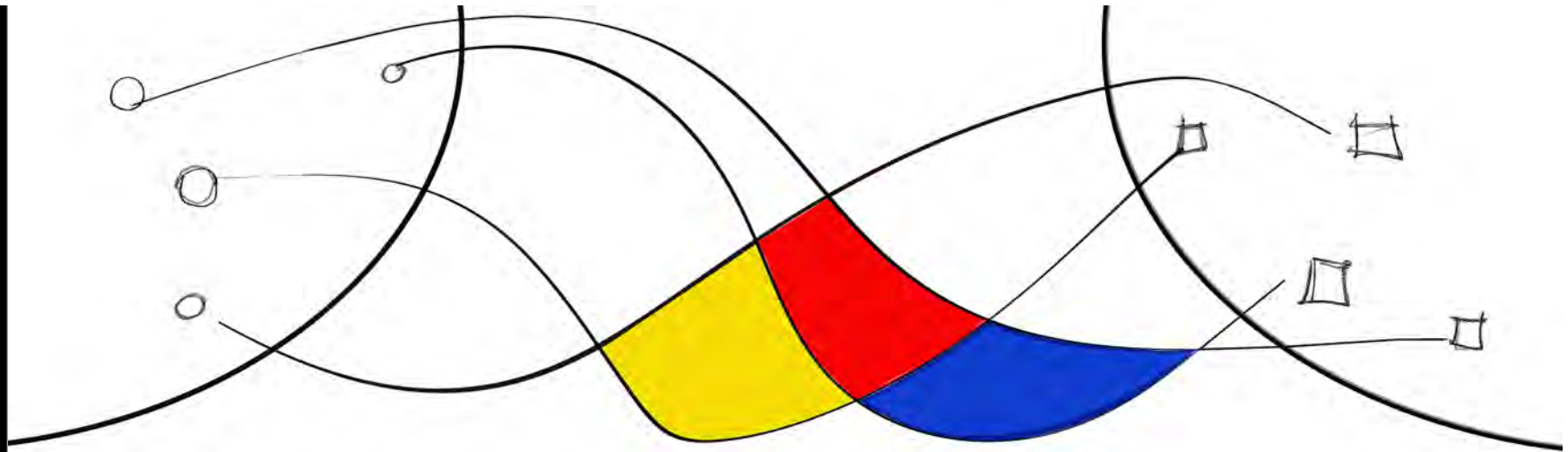

CONCEPT SOLUTION



Introduction

Method

Case study

Implication
and
conclusions



Introduction

Method

Case study

Implication
and
conclusions



Introduction

Method

Case study

Implication
and
conclusions



Introduction

From our experience in Montenegrin real estate market, this approach helped several developers:

Method

to **create** adequate **development strategies**

contributed **upgrading the value of a site**

fastening up the **land acquisition** phase.

Case study

Implication
and
conclusions



From our experience in Montenegrin real estate market, this approach helped several developers:

to **create** adequate **development strategies**

contributed **upgrading the value of a site**

fastening up the **land acquisition** phase.

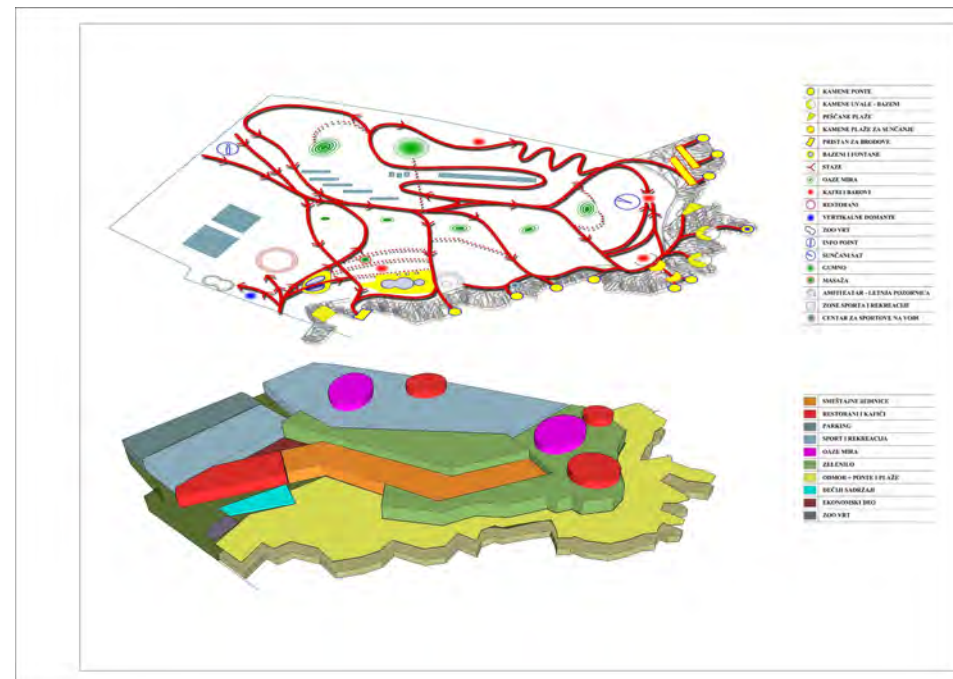

From our experience in Montengrin real estate market, this approach helped several developers:

to **create** adequate **development strategies**

contributed **upgrading the value of a site**

fastening up the **land acquisition** phase.



From our experience in Montengrin real estate market, this approach helped several developers:

to **create** adequate **development strategies**

contributed **upgrading the value of a site**

fastening up the **land acquisition** phase.



From our experience in Montenegrin real estate market, this approach helped several developers:

to **create** adequate **development strategies**

contributed **upgrading the value of a site**

fastening up the **land acquisition** phase.



From our experience in Montenigrin real estate market, this approach helped several developers:

to **create** adequate **development strategies**

contributed **upgrading the value of a site**

fastening up the **land acquisition** phase.



From our experience in Montenegrin real estate market, this approach helped several developers:

to **create** adequate **development strategies**

contributed **upgrading the value of a site**

fastening up the **land acquisition** phase.



From our experience in Montenegrin real estate market, this approach helped several developers:

to **create** adequate **development strategies**

contributed **upgrading the value of a site**

fastening up the **land acquisition** phase.



From our experience in Montenegrin real estate market, this approach helped several developers:

to **create** adequate **development strategies**

contributed **upgrading the value of a site**

fastening up the **land acquisition** phase.



From our experience in Montenegrin real estate market, this approach helped several developers:

to **create** adequate **development strategies**

contributed **upgrading the value of a site**

fastening up the **land acquisition** phase.



From our experience in Montenegrin real estate market, this approach helped several developers:

to **create** adequate **development strategies**

contributed **upgrading the value of a site**

fastening up the **land acquisition** phase.



From our experience in Montengrin real estate market, this approach helped several developers:

to **create** adequate **development strategies**

contributed **upgrading the value of a site**

fastening up the **land acquisition** phase.



Introduction

Method

Case study

Implication
and
conclusions

From our experience in Montenegrin real estate market, this approach helped several developers:

to **create** adequate **development strategies**

contributed **upgrading the value of a site**

fastening up the **land acquisition** phase.

This approach could contribute developing strategy in situations that lack relevante data.

This approach could expand the possibilities in use of urban and architectural design in qualitative research in development process.



Introduction

Method

Case study

Implication
and
conclusions

Thank you for your attention!

www.pulsarh.com

