

# INTEGRATING WORKFLOW MODELING AND 3D CAD FOR VISUALIZING PROJECT PERFORMANCE

**Anthony D. Songer<sup>1</sup>, Prasad S. Subramanian<sup>2</sup>, and James E. Diekmann<sup>3</sup>**

1. Asst. Prof., Dept. of Civil, Environmental, and Architectural Engr, University of Colorado, CB 428, Boulder, Colorado 80302
2. Graduate Research Assistant, Dept. of Civil, Environmental, and Architectural Engr, University of Colorado, CB 428, Boulder, Colorado 80302
3. Prof., Dept. of Civil, Environmental, and Architectural Engr, University of Colorado, CB 428, Boulder, Colorado 80302

*ABSTRACT: Construction projects are becoming increasingly difficult to manage using traditional project control methods. Although computer applications have the potential to change or improve upon the traditional methods and practices current computer-based tools are static, reactive reporting systems focusing on individual applications. Providing dynamic feedback for the underlying construction processes (procurement, RFI etc...) creates a proactive management environment necessary for complex, time sensitive, collaborative project delivery. This paper suggests the integration of Workflow Management Systems and 3D CAD as a tool for visual project control.*

**KEYWORDS:** Workflow, Workflow Management Systems, 3D CAD, Integration.

## INTRODUCTION

Demands of the New Economy are driving fundamental changes in traditional project delivery techniques. One outcome is the requirement for rapid delivery through highly collaborative efforts. Project control methods must be aligned with the changing delivery environment. Traditional project control methods that focus on periodic calculations of cost/schedule variance must be replaced by real time process control providing a proactive control environment. Such change is consistent with the concepts of improved coordination, transparency and dynamic control permeating through the industry (Womack 1996, Ballard & Howell 1996).

Current use of computer-based tools are being leveraged meet the demands of the construction industry by way of better management of information and faster execution of tasks like plan/schedule preparation, cost estimating, etc. The integration of 3D CAD models with schedule/cost estimating applications and databases (Akinci and Fischer 1998, Riley 1998, Songer et. al. 1998, Staub and Fischer 1998) provide improved information management, visualization and automation of tasks. However, these tools have focused on individual applications. Information management is restricted to storing and retrieving information from databases. Since databases do not have any information regarding the processes, these tools are incapable of automating and coordinating processes. Managing and coordinating collaborative design and construction processes necessitates the reinvention of traditional project control tool. This paper introduces the



concept of integrating workflow management systems and 3D CAD for creating dynamic process control mechanisms. Specifically, the paper investigates the usefulness of workflow management systems in the construction industry, differentiates process and workflow, and introduces the concept of workflow management. The paper then discusses the value adding features of workflow applications on the value chains of the construction industry. The paper also discusses a prototype that suggests the integration of workflow management systems with 3D CAD models to enhance visualization of change of state in a process and aid project control.

## PROCESS AND WORKFLOW

A process model describes the structure of a business process in the real world. It defines all possible paths through the business process, including the rules that define which path to take and what actions to perform. This paper considers an instance of the business process model as a workflow. Figure 1 illustrates the three dimensions to workflow.

- Process logic: This defines the tasks and their logical sequence for performance.
- Roles: This information defines “who” (human/system) will perform the task.
- Resources: This information defines “what” resources or applications, the roles require to perform the tasks.

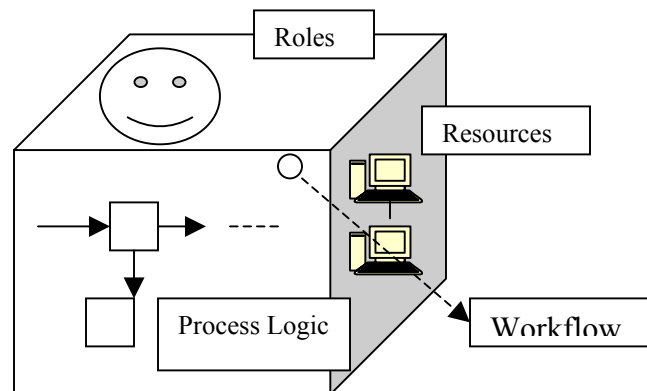

Figure 1. The three dimensions of workflow.

A workflow does not necessarily run on a computer. Most parts of processes in the construction industry today including supply chain, RFI clarifications, change order, billing, deployment of labor, etc. are under manual control. However, computer assistance in the form of Workflow Management systems provides great potential for better information management, improved coordination and administration/control.

## WORKFLOW MANAGEMENT SYSTEMS

Computer based tools of today, for construction management, are information centric. They facilitate the transfer or sharing of information from workgroup to workgroup or individual to individual. The key ingredient is information. Information management is restricted to storing and retrieving information from databases. A change in information in a database represents a change of state in a process but nowhere in the database is a

representation of what caused the change or what the change aims at. In other words, databases contain no knowledge about the processes (Leymann and Roller, 2000). On the other hand, workflow-based applications (WA) are process centric in that they additionally manage, transfer, share and route the process knowledge that applies to the information. The process knowledge includes schedules, priorities, authorizations, security and the roles of each individual involved in the process. Thus, the WA emphasizes the importance of the process, which acts as a container for the information. In this way, WA combines rules, which govern the tasks performed, and coordinates the transfer of the information required to support these tasks. A Workflow Management System (WfMS) comprises many such WA and helps to define and carry out business processes in a heterogeneous and distributed environment. They make sure that within a business process, the right people/systems/applications, with the right data, using the right tools, perform the right activity at the right time, at the right place.

The Workflow Management Coalition describes the WfMS as one that provides procedural automation of a business process by management of the sequence of work activities and the invocation of appropriate human and/or IT resources associated with the various activity steps (WfMC-Hollingsworth, 95). The WfMS makes this possible by providing support in three functional areas:

- The Build-time functions, concerned with defining, and possibly modeling, the workflow process and its constituent activities.
- The Run-time control functions concerned with managing the workflow processes in an operational environment and sequencing the handling of various activities as part of each process.
- The Run-time interactions with human users and IT application tools for processing the various activity steps.

The following sections provide a briefly discussion of each of the above functional areas.

### **Build-Time Functions**

In order that the computer understands the logic of the process and executes accordingly, the translation of the definition of the process in a computer understandable language is necessary. The build-time functions help in building the process definition that the computer understands.

### **Run-Time Process Control Functions**

This software interprets the process definition and creates and controls workflows i.e. instances of the process. This involves scheduling the various activities in the process, invoking appropriate human or IT resources etc. This software resides in a number of computer platforms to cope with the processes that operate over different geographical positions.

## Run-Time Activity Interactions

Each activity or task in the workflow requires a human or systems application for execution. There is interaction with the process control software to transfer control between activities, to ascertain the operational status of processes, to invoke application tools and pass appropriate data to the human participant or the systems application.

In a typical WfMS, the interface for users is a graphical user interface (GUI) that can be a web browser on a network station, or a window on a Personal Computer (PC) or a hand-held device. The users receive their tasks as work items in their “in-box”. The process administrator’s user interface gears toward managing process instances and acting as a focal point of all process related events.

## Workflow Architecture – A Top Level View

Figure 2 provides the top-level view of the workflow architecture. One or more workflow engines govern the flow of activities in a business process shown in the central box. Depending on requirement, the workflow engine starts appropriate applications and gets the necessary data from the database to enable the participant to perform the task. Distribution of the control of workflow is; (i) across the workflow engines, (ii) held in one master engine, (iii) held as a shared resource in a file store, or (iv) a combination of these.

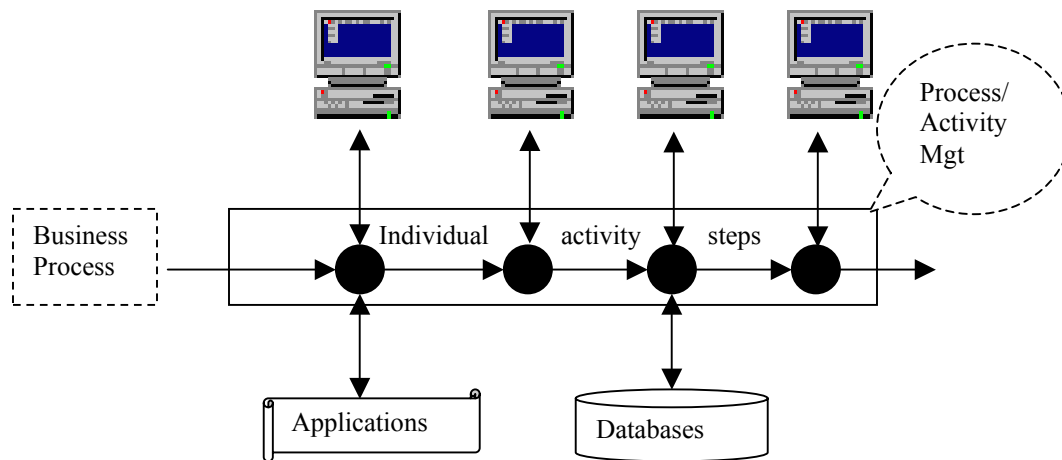

*Figure 2. Top Level View of the Workflow Architecture (WFMC-Hollingsworth, 95)*

The following section discusses the usefulness of workflow management by focusing on the value chains in construction.

## INFLUENCE OF WfMS ON THE VALUE CHAIN

A valuable framework for considering how workflow systems can contribute to management has its basis with the concept of the value chain. The value chain views any firm as a collection of activities that add value to the product or service of an organization (Porter, 1985). For instance, the steel fabricator adds value when s/he receives the raw materials, fabricates them to make steel pieces ready for installation according to shop

drawings and ships them to the job site. This value chain is profitable if the installation of the steel piece meets the specifications on the job site and the job receives a price for it that exceeds the cost of creating the value. Therefore, the value chain provides a specific framework for the assessment of the critical areas when facilitated by the automation of workflow. The value chain analysis determines those areas where a workflow system facilitates the critical transformation of data into information and knowledge, which in turn can yield great benefits.

Benefits throughout the value chain enhanced through a workflow management perspective include coordination, cross-organizational linkage, timeliness, reduced vulnerability, and dynamic control.

### **Coordination**

The cost of creating value is a function of how well the activities in the value chain are coordinated and integrated. A poorly structured value chain may result in delays during the transfer of resources from one task to another. For instance, it is common to note that the fabricator has no information about the schedule on the job site. If there is a delay by the fabricator in shipping the fabricated material, there will be a delay in the erection of the steel structure on the job site. If the erection activity is on the critical path, the cost of creating value will surely exceed the price received. A workflow system has the necessary information to avoid such a consequence. It improves the coordination between the fabricator and the job site and warns the management ahead of time of any uncertainties.

### **Links across Organizational Boundaries**

The value chain is a system of interdependent activities connected by linkages. Linkages occur when the performance and execution of one activity affects other activities. For example, the fabrication of the steel component affects its installation on the job site. Linkages could be internal and external. Internal linkages connect activities within an enterprise while the external linkages connect activities of one enterprise with another like the supplier or the fabricator etc. A WfMS handles both internal and external linkages thus enabling many disparate applications and environments to work together. Workflow between companies and organizations means that the initiation of a transaction results in the triggering of an entire process that may involve actions by several entities, both manual and automated. This feature is especially beneficial in the construction community since every project comprises participants from different companies i.e. sub-contractors, suppliers/vendors, specialty contractors etc.

### **Time Saving on the Value Chain**

Another important element in the value chain is time. The time required to complete a task is the task time and the time between tasks is the transfer time. In the construction industry, there is always a great amount of time lost between tasks. For instance, in the Request for Information (RFI) process demands the participation of the sub contractor, the contractor, the project manager and the architect/structural engineer. Very often, there is considerable amount of time lost in transfer of documents and drawings between the

participants. Workflow systems address both task and transfer time and can effectively collapse the idle period between tasks thus compressing the cycle time of the process. Since workflow systems make resources, e.g. design-drawings, available to the participant along with the allocated task, the participant saves considerable time in not searching for the relevant documents. The integration of 3D CAD model with the workflow system adds further value to the presentation of resources to the participants in construction.

### **Reducing Vulnerability**

The introduction of workflow management technology requires thorough investigation of the processes before implementation. Such detailed study results in increased knowledge about the group processes. This knowledge is useful to reschedule, defer or prioritize work to reduce its vulnerability (Jablonski, 1996).

### **Dynamic Control**

The workflow management system provides real-time status of the processes to management and participants throughout the value chain. Integration of the Workflow Management System with a 3D CAD model provides visual indications of the status of the different underlying processes e.g. procurement, RFI etc. The management thus has the opportunity to relate the status to the schedule of activities on the job site and take necessary action to avoid obstacles, if any. Thus, the WfMS enhances transparency and provides opportunity for dynamic control on the value chain. A discussion of a prototype that demonstrates the integration of workflow with a 3D CAD model follows.

### **INTEGRATION OF 3D CAD WITH WfMS – A PROTOTYPE**

Design of the facility is the core of most processes in a construction project. The traditional design drawings are vulnerable to numerous errors that bring in unwanted delays in a project. Being able to view the design in 3D from a single source avoids many interpretation problems on the job site. Integration of the 3D design with workflow will further enhance visualization on the user interface of a workflow management system for dynamic control of processes. The following prototype considers the RFI process and demonstrates the link between an RFI workflow and a 3D design model.

The authors use Petri Nets to define the flow of the RFI process. Petri Net (PN) is a formal graphical modeling tool that has been widely used to model/define a workflow process. Structural properties of the model and performance evaluation are directly available from PN models. When compared to other modeling schemes such as queuing theory and discrete event simulation, PNs are generally considered to be superior for systems with concurrency, where several state changes happen simultaneously and where event driven characteristics are present. Both of these phenomena are present in construction systems (Wakefield and Sears, 1997).

The simulations of Petri Nets graphically demonstrate the behavior of a WfMS. This simulation exhibits the navigation through the process as well as the performance of the process. It maintains all unperformed actions as events in a queue. These events include

requests such as start a process, navigate to the next activity or finish a process. State information is available for all resources, such as people, so simulation can account for business processes that compete for resources. Petri net simulation thus supports all dynamic aspects of business processes

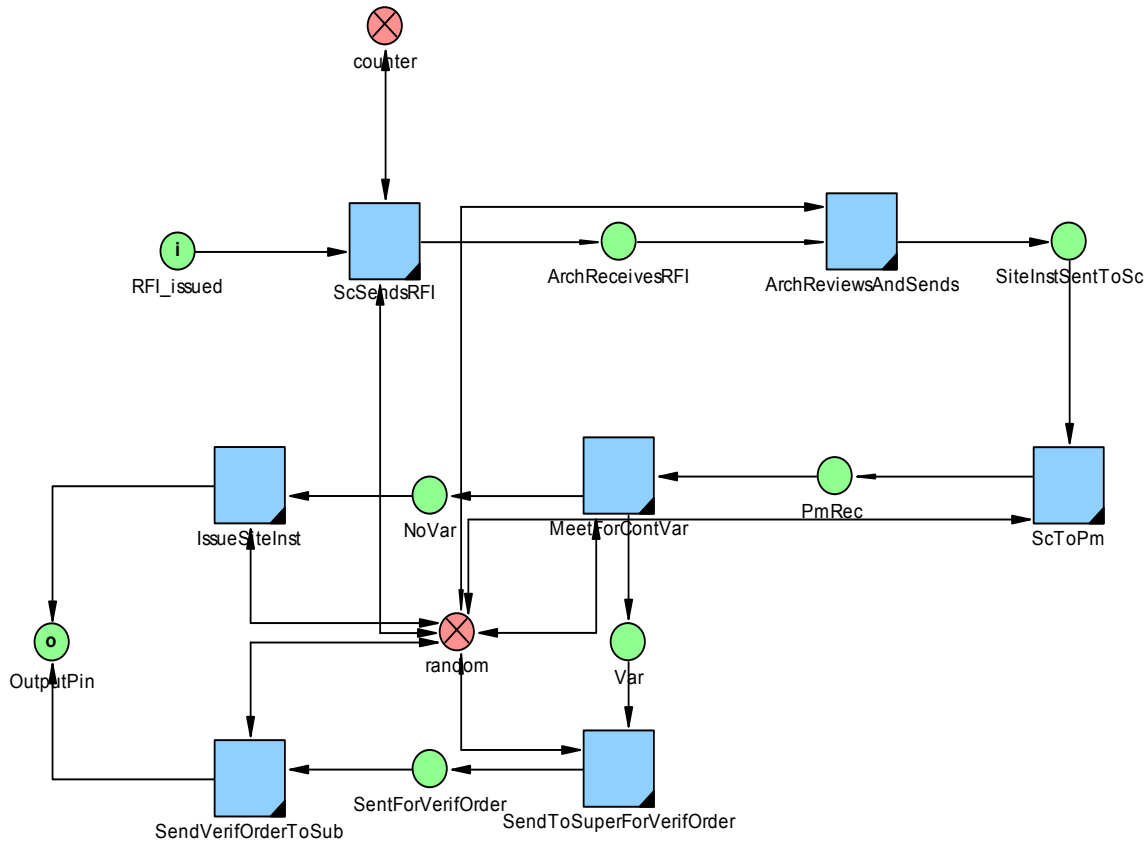

Figure 3. Screen shot of a Petri Net model of the RFI process used in the prototype.

The figure above is a screen shot of a Petri Net model of the RFI process from ‘Exspect’, a Petri Net simulation software.

The squares represent transitions and the circles represent states. The main participants of the process are the architect/structural engineer, the sub contractor and the project manager. The process definition is as found on most job sites (Mohamed et al., 1999). The site clerk receives the RFI from the sub contractor/initiator and sends it to the architect. The architect reviews the problem and sends a solution back to the site clerk who then sends it to the Project Manager. The project manager meets with the sub contractor/initiator to investigate any contract variance. If there is no variance, the project manager issues site instructions. Otherwise, the project manager sends the documents to the superintendent for a verification order.

Following is a transition-sequence-chart showing the roles involved in the process and the transfer of control by transitions. Such a sequence chart is available on a dashboard in the user interface and gives such details as to ‘who’ is performing ‘what’ activity at a given time as the workflow progresses.

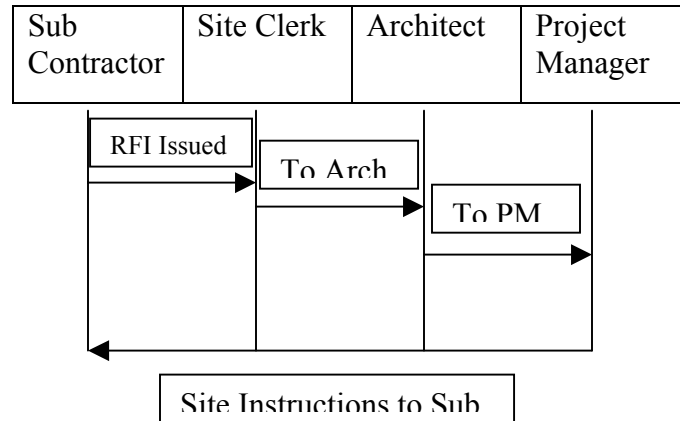

Figure 4. Transition Sequence Chart

The movement of a token in a PN represents the flow of the process. During simulation, in Exspect, it is possible to pass the values of the tokens as arguments to an executable. In the prototype, this executable, written in Java, parses the value of the token and updates the fields in a database using the JDBC-ODBC Bridge. The database maintains data that is relevant to the flow of the process i.e. expected dates of execution by participants, actual dates of execution, throughput time once the workflow is complete etc. Thus, we now have a system that updates the database with relevant data at each stage of the process during simulation.

The 3D CAD model links to this database. Bentley Systems Inc.’s Enterprise Navigator displays the 3D CAD model. The model is object oriented in that the different components of the facility are objects. Thus, the roof is an object, the walls are objects, etc. Bentley’s Class Editor allows one to create classes and instance objects from database records. The Class Editor also allows building of relationships between these objects and the graphical objects. Using the relationships, depending on the values of the properties on the database object, a color can highlight the graphical object. For instance, an RFI issued on the job site will instance a database object that will be in association with a design object on the 3D CAD model. The event instantly highlights the object on the graphical model. The management gets an instant visual indication of the existence of the RFI and its physical location on the design. Similarly, if there is a bottleneck on the process that delays the transitions beyond their expected dates, the event highlights the object on the graphical model indicating a failure. The management thus gets instant visual notification and has the opportunity to act on the problem immediately. In this way, any number of underlying processes can be under control real time. Figure 5 below shows two processes, the procurement process and the RFI process. The figure also shows the links between the Petri Net model, the database and the 3D CAD model.



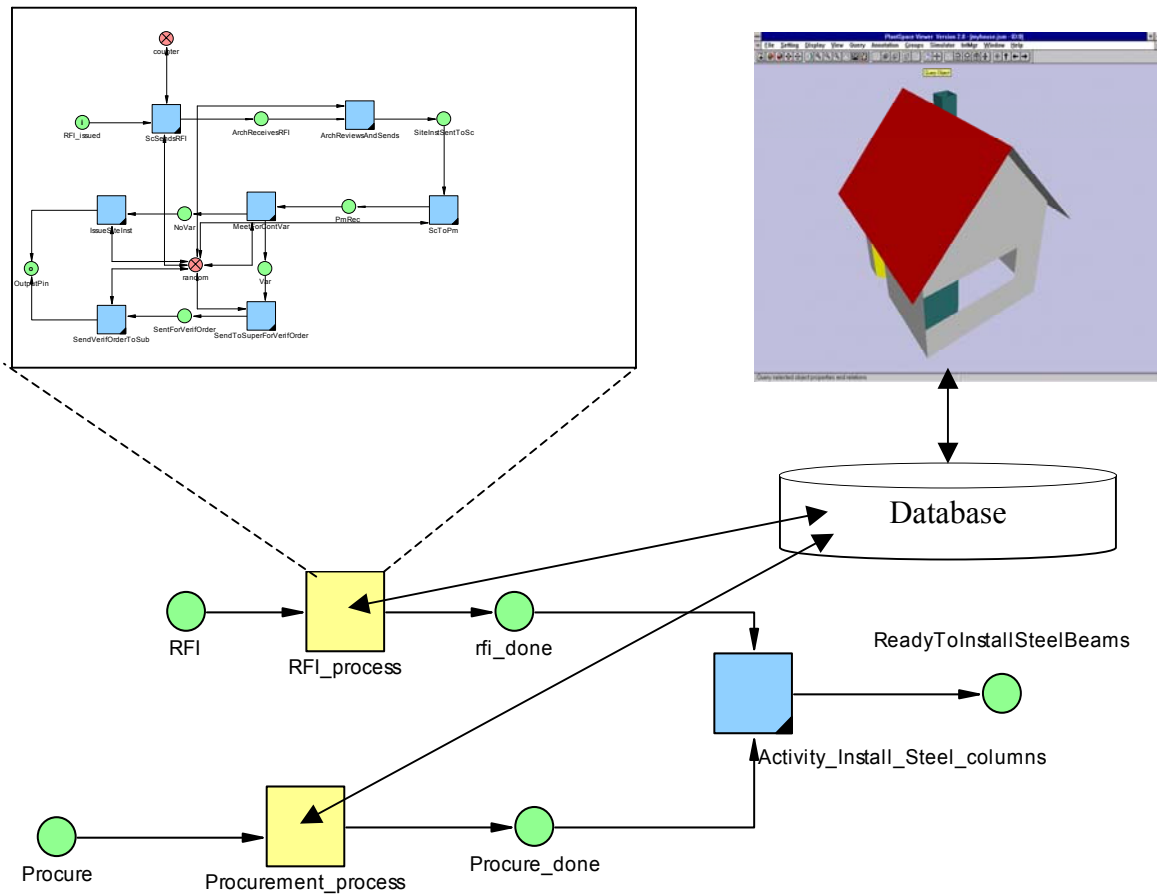

Figure 5. Schema of the Prototype

### The Future Path Prediction

From this integration arises the concept of ‘Future Path Prediction’. Various underlying work processes provide input to construction activities. Material has to reach the site, RFIs related to the activity, if any, need to be resolved, change orders, if any, need to be negotiated, shop drawings from the fabricator have to be received etc. Completion of such processes, concurrent or non-concurrent, is a prerequisite for the commencement of an activity on the job site. The WfMS keeps track of the individual processes, performance measures in the background, and the overall sequence of construction activities on the job site. The system contains information regarding the status and the performance of the processes and uses this information to logically predict any bottlenecks, failures or uncertainties that might affect the start of an activity or a work item in the downstream or the “future path”.

A description of the concept is available in (Subramanian, P., et. al, 2000).

## CONCLUSION

Workflow management software is a proactive computer system that manages the flow of work among participants, according to a defined procedure consisting of a number of tasks. It coordinates user and system participants, together with appropriate data resources to achieve defined objectives by set deadlines. The coordination involves passing tasks from participant to participant in correct sequence, ensuring that all fulfill their required contributions. Workflow Management Systems have the potential to add value to the value chain in construction by improving coordination, reducing throughput time, reducing cost and providing the opportunity for dynamic control. Since design is the core of most construction processes, the integration of 3D CAD with workflow management software provides improved visualization for dynamic control of processes and enables better understanding of the problem, if any, with respect to the design. The paper describes a prototype that illustrates the concept. From the integration of WfMS and 3D CAD arises the concept of Future Path Prediction that is a useful project control tool for a dynamic proactive control environment.

## REFERENCE

- **Abbot K. R., Sarin S. K.,** (1994) *Experiences with Workflow Management: Issues for the Next Generation, CSCW '94*, Proceedings of the Conference on Computer Supported Cooperative Work.
- **Akinci B., Fischer M.,** (1998). *Time-Space Conflict analysis Based on 4-D Production Models*, Computing in Civil Engineering, Proceedings of the International Computing Congress.
- **Ballard G., Howell G.,** (1996). *Can Project Controls do its job?*, Proceedings of The International Conference on Lean Construction.
- **Ballard G., and Howell G.,** (1998). *Shielding Production: Essential Step in Production Control*, ASCE Journal of Construction Engineering and Management.
- **Jablonski S., Bussler C.,** (1996). *Workflow Management – Modeling Concepts, Architecture and Implementation*, International Thomson Computer Press.
- **Leymann F., Roller D.,** (2000). *Production Workflow – Concepts and Techniques*, Prentice Hall.
- **Liston K. M., Fischer M., and Kunz J.,** (1998). *4-D Annotator: A Visual Decision Support Tool for Construction Planners*, Computing in Civil Engineering – Proceedings of the International Computing Congress.
- **Mohamed, S., Tilley, P.A., and Tucker, S.N.,** (1999). Quantifying the time and cost associated with the request for information (RFI) process in construction, International Journal of Construction Information Technology, 7(1).
- **Porter M.,** (1985). *Competitive Advantage – Creating and Sustaining Superior Performance*, Collier Macmillan Publishers.
- **Riley D. R.,** (1998). *4-D Space Planning Specification Development for Construction Work Spaces*, Computing in Civil Engineering, Proceedings of the International Computing Congress.

- **Sadonio M., Tommelein I. D., Zabelle T. R.,** (1998) – *The Last Designer’s CAD-Database for Sourcing, Procurement, and Planning*, Computing in Civil Engineering, Proceedings of the International Computing Congress.
- **Songer A. D., Diekmann J., and Al-Rasheed K.,** (1998). *The Impact of 3-D Visualization on Construction Planning*, Computing in Civil Engineering, Proceedings of the International Computing Congress.
- **Subramanian, P., Songer, A.D., and Diekmann, J.,** (2000). Visualizing Process Performance, Proceedings of the 8<sup>th</sup> International Conference on Computing in Civil and Building Engineering, Stanford, CA.
- **Tilley P., Adam Wyatt A., and Mohamed S.,** (1997). *Indicators of Design and Documentation Deficiencies*, Proceedings of the International Conference on Lean Construction.
- **Wakefield R. R., Sears G. A.,** (1997), *Petri Nets for Simulation and Modeling of Construction Systems*, ASCE Journal of Construction Engineering and Management.
- **Womack J. P., Jones D. T.,** (1996). *Lean Thinking*, Simon & Schuster.
- **Workflow Management Coalition**, various publications available at: <http://www.aiim.org/wfmc>